

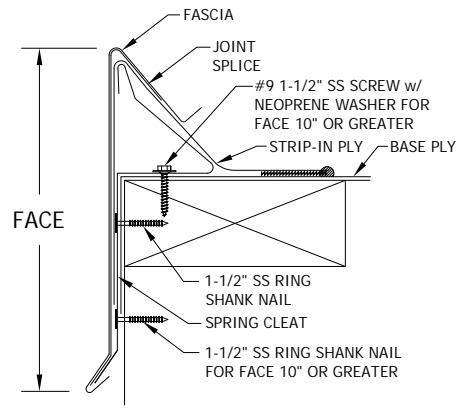

Installation Guide for SecurEdge 300 Fascia



ANSI/SPRI ES-1 TESTED



NOTES:

#1 - Isolate all metal parts from ACQ treated wood or other galvanically incompatible material with appropriate membrane material.

#2 - Appliance attachments, such as lightning rods, signs, or antennae that penetrate the water seal, induce a galvanic reaction, or otherwise compromise the effectiveness of the roof edge system, shall be eliminated or isolated to prevent problems per section 8.0 of ANSI/SPRI ES-1. It is recommended that appliances be isolated from or not attached to the roof edge system. Consult the lightning protection system manufacturer for specific attachment instructions.

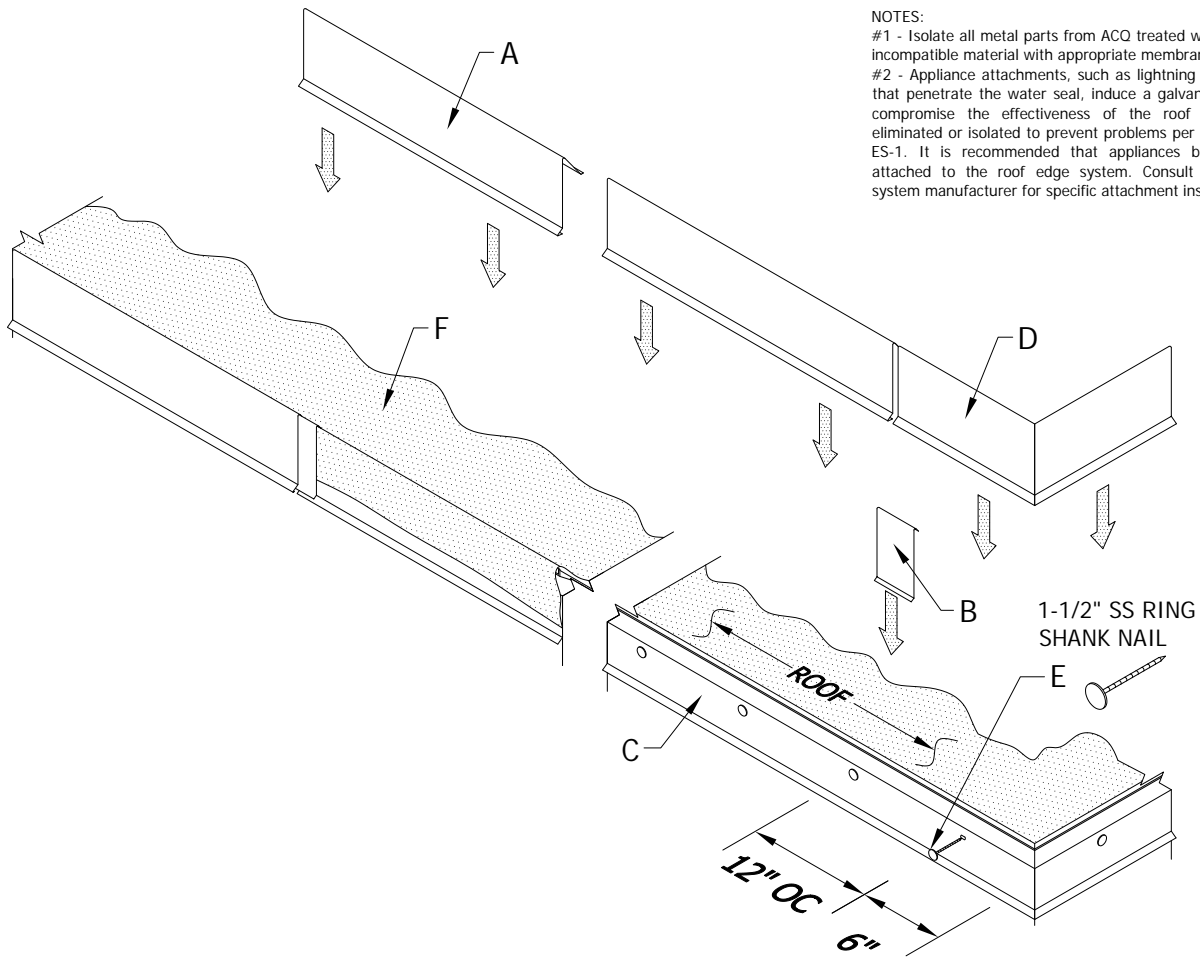

A. Formed Fascia Cover
10'-0" Lengths

B. Concealed Joint Splice
4" Lengths

C. Galvanized Steel Spring Cleat
10'-0" Lengths

D. Fascia Miter Cover
(Outside Corner Shown)

E. 1-1/2" SS Ring Shank Nail
at 12"o.c. (6" from ends)
(Provided & Required by Manufacturer)

F. Approved Strip-in Ply Membrane
(By Installer)

CARLISLE SYNTEC INCORPORATED

P.O. BOX 7000 - CARLISLE, PA 17013 - Phone: (800) FOR-SYNTEC - Fax: (717) 245-7245

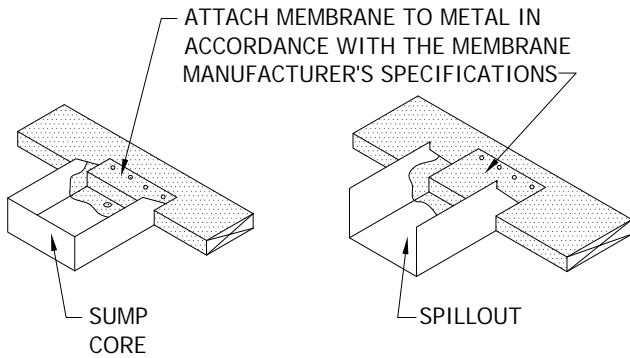

STEP 1: Consider Sump Core & Spillover Locations

Locate sump cores where downspouts will be located. Sumps are installed prior to the spring cleat. The spring cleat butts up to side(s) of sump core. Spillovers are installed along with the fascia lengths as required. Refer to "Spillover & Sump Core Install Guides" for more info on installation if necessary.

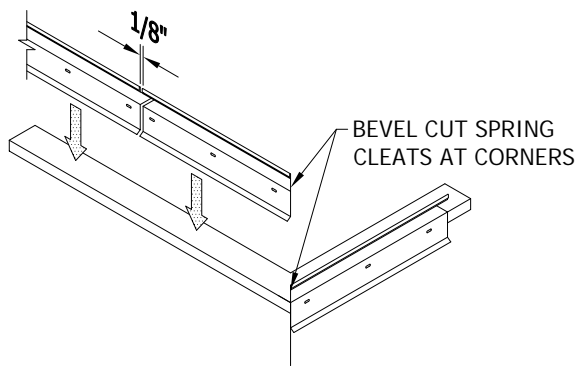

STEP 2: Installing Spring Cleat

Prior to installing the spring cleat, ensure that all metal components have been isolated from ACQ treated lumber with appropriate membrane material. Field cut spring cleat to fit corner conditions. Install spring cleat working away from corners. Allow 1/8" gap between sections for thermal movement. Mechanically fasten the spring cleat using the 1-1/2" ss ring shank nails provided in each pre-punched holes.

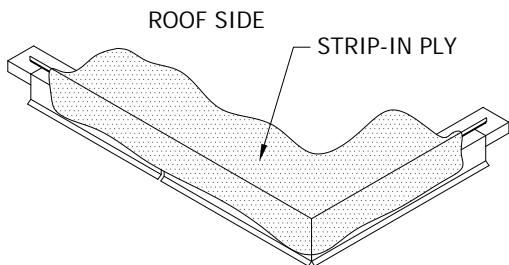

STEP 3: Installing Strip-in Ply

Install the strip-in ply in accordance with the manufacturer's specifications. Strip-in ply should extend down the vertical surface of the spring cleat.

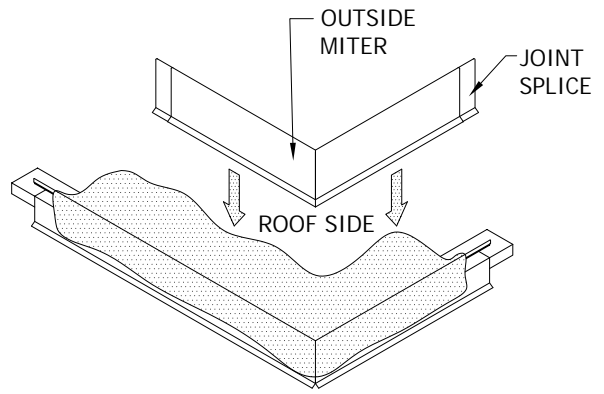

STEP 4: Installing Fascia Miters

Locate the miter and concealed joint splice for the appropriate corner. Place a concealed joint splice in each side of the miter. Center the cover over the spring cleat, then pressing downward on the top of the miter until the drip of the miter fully engages the drip of the spring cleat. Miters have 24" nominal leg lengths.

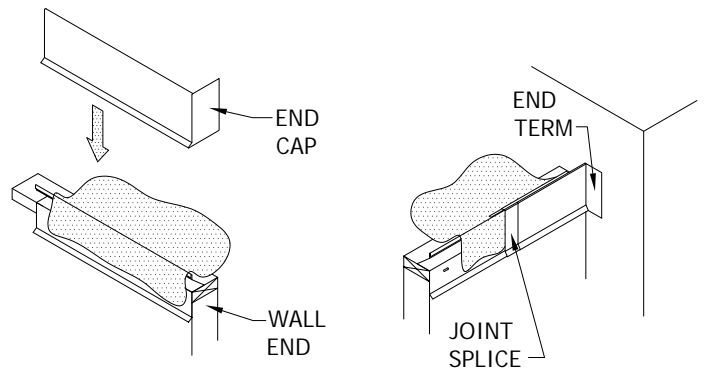

STEP 5: Installing Fascia End Caps and End Terms

Install the fascia end caps and end terms by pressing downward on the top flange until the drip of the fascia has fully engaged the drip of the spring cleat. Ensure that the drips have fully engage each other.

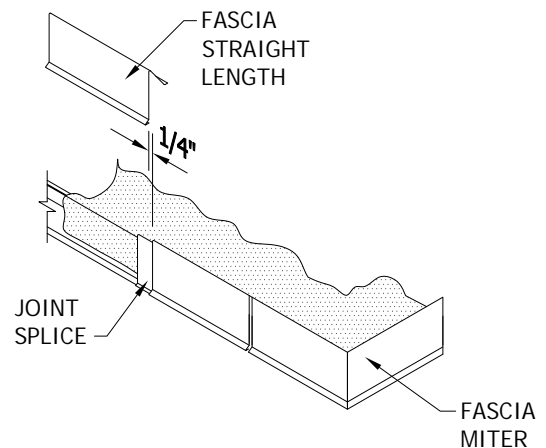

STEP 6: Installing Fascia Straight Lengths

Place a concealed joint splice in the opposite end of the installed miter or end cap. Install the fascia by pressing downward on the top flange until the drip of the fascia has fully engaged the drip of the spring cleat. Allow 1/4" gap between fascia sections for thermal expansion. Lengths of all straight pieces should be considered prior to cutting to avoid creating relatively short sections of fascia adjacent to full length sections.

Note: there should be a joint splice at every joint.