

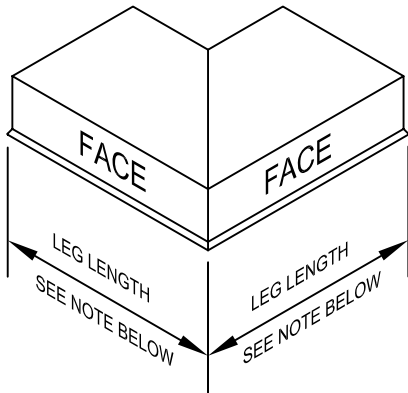

# Perlok 150 Coping

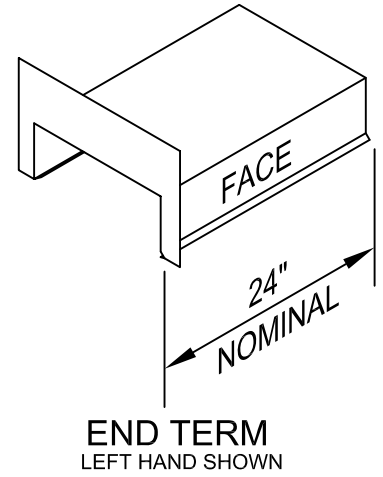

OUTSIDE CORNER

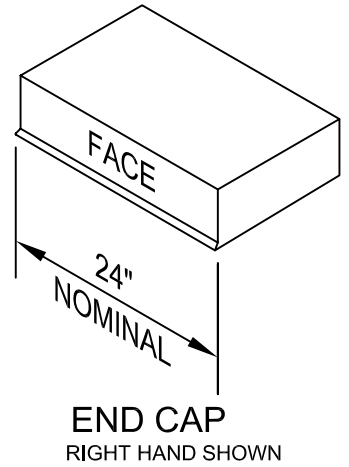
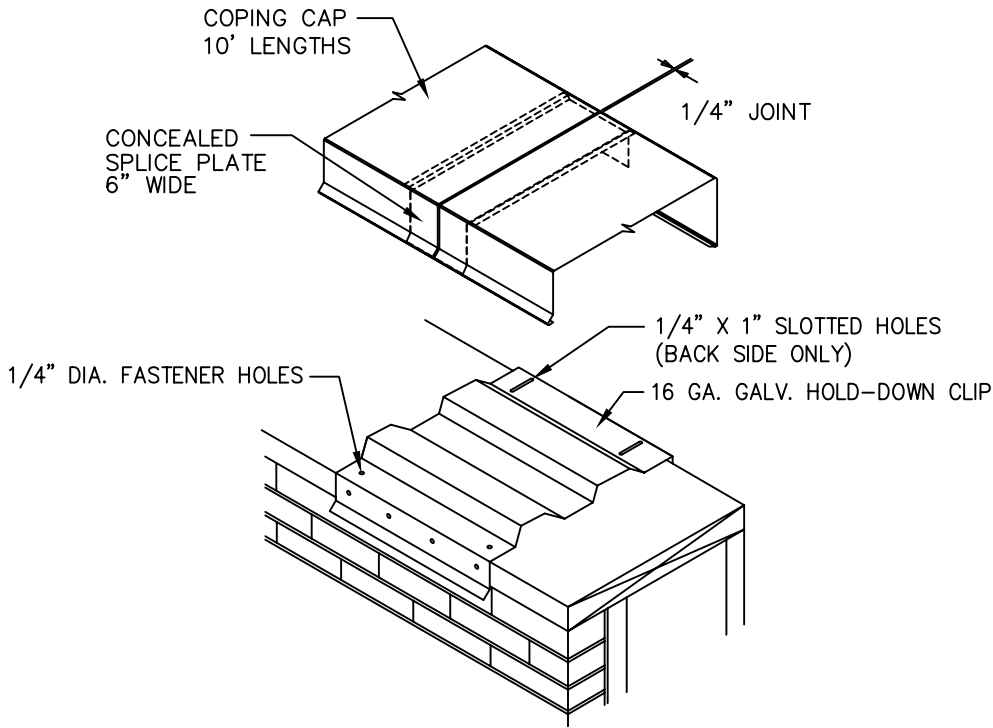
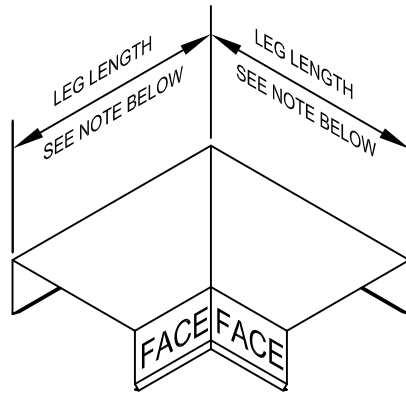

INSIDE CORNER

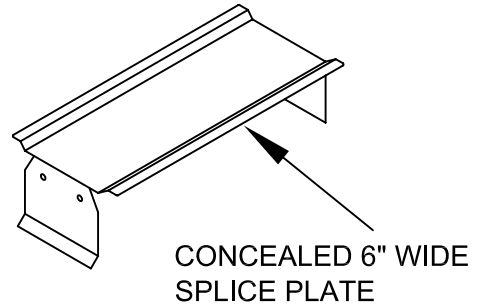

STANDARD COPING CORNERS LEG LENGTHS:  
 LENGTH = 23 1/4" FOR 6" - 16" WALL WIDTHS  
 LENGTH = 29 1/4" FOR 17" - 23" WALL WIDTHS  
 LENGTH = CUSTOM FOR WALL WIDTHS > 23"

FOR SPECIAL CORNER REQUIREMENTS, ATTACH SKETCHES, OR  
 CONSULT MFR. FOR ASSISTANCE.