

QUICK SHIP PROGRAM:

Next day shipping, limited to the following colors: Stat. Bronze, Med. Bronze, Sandstone, Bone White, Sierra Tan, Shale Gray, Dove Gray, Concord Cream, Mill, Clear Anodize (Aluminum Only)

QUANTITY: _____ Total LF _____ Miters (____ Outside, ____ Inside) _____ End Caps - Inserts (____ Left, ____ Right) _____ End Terms - Inserts (____ Left, ____ Right)	MATERIAL: <input type="checkbox"/> 0.040 Aluminum <input type="checkbox"/> 0.050 Aluminum <input type="checkbox"/> 24ga Galvanized SHIPPING: <input type="checkbox"/> Quick Ship Program	ACCESSORY TYPE: All Accessories are Metal-lock	FINISH: <input type="checkbox"/> Mill Finish <input type="checkbox"/> Prefinished Kynar <input type="checkbox"/> Clear Anodize
			COLOR: _____

APPROVALS: ANSI/SPRI ES-1 TESTED	CUSTOMER APPROVAL: <input type="checkbox"/> Approved for Fabrication <input type="checkbox"/> Approved with Changes <input type="checkbox"/> Disapproved, Resubmit	_____ Authorized Customer Signature _____ Title Date
Job Name: _____	Customer: _____	By: _____
Job #: _____	Representative: _____	Date: _____
Location: _____	Architect: _____	Sheet _____ of _____

EconoEdge Coping

NOTE:

Starting at the corners, notch the drip on both legs so that the adjoining part can overlap it. Each subsequent straight length will require the drip to be notched at one end.

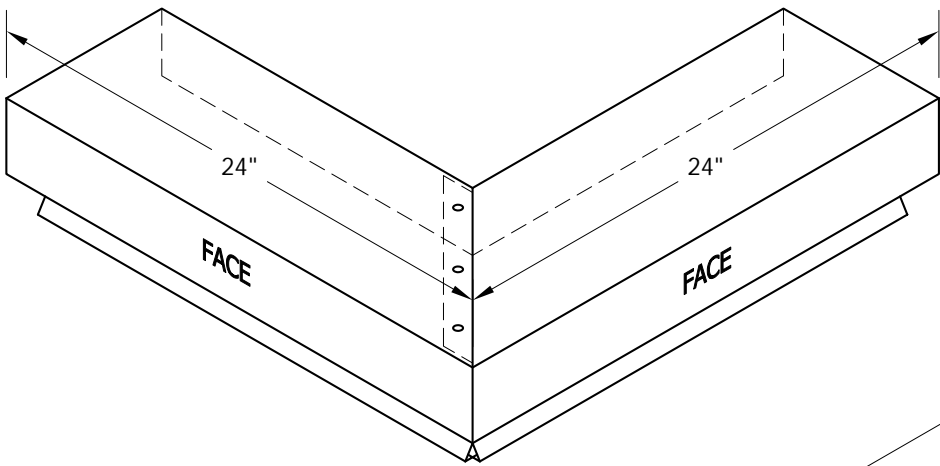

OUTSIDE CORNER

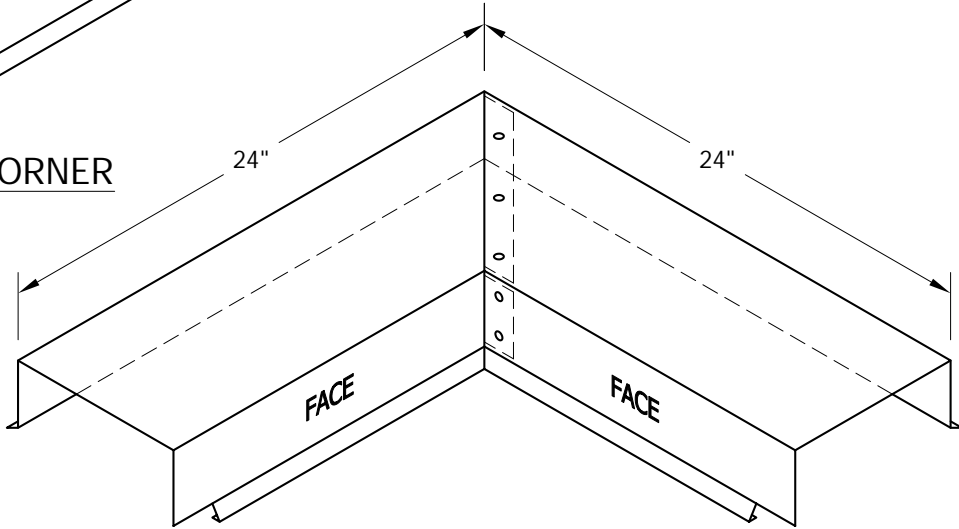

INSIDE CORNER

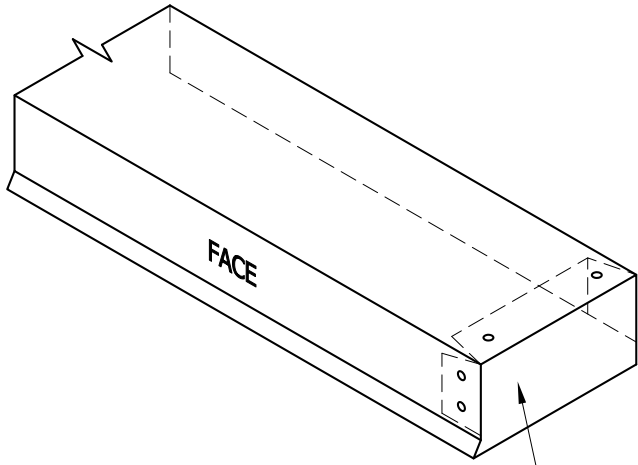

END CAP
RIGHT HAND SHOWN

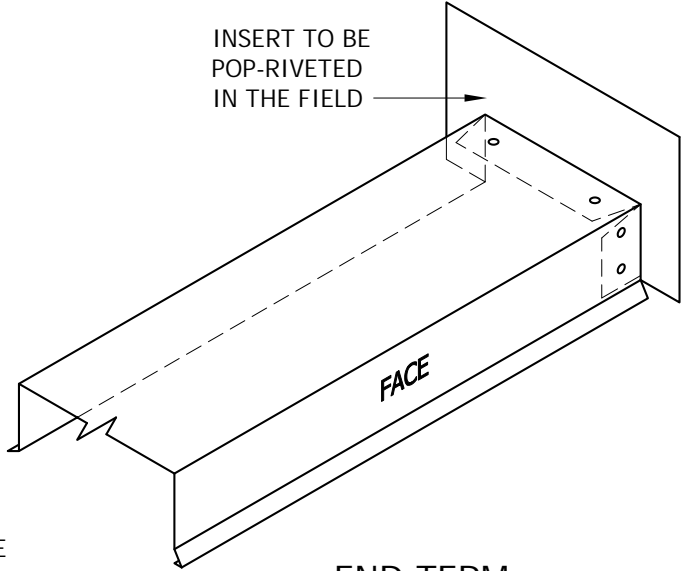

END TERM
RIGHT HAND SHOWN