

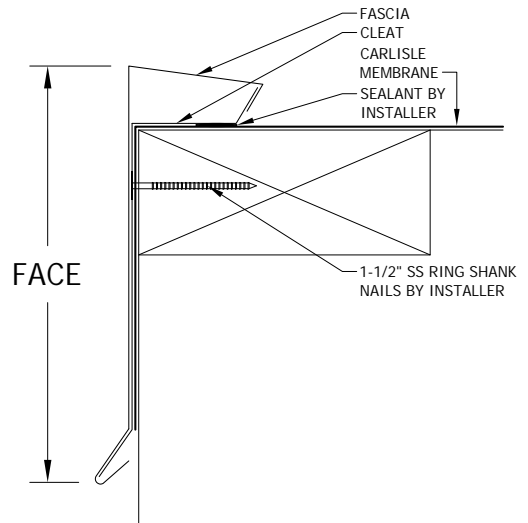

# Installation Guide for EconoEdge Retainer Fascia

ANSI/SPRI ES-1 TESTED



**NOTES:**

#1 - Isolate all metal parts from ACQ treated wood or other galvanically incompatible material with appropriate membrane material.

#2 - Appliance attachments, such as lightning rods, signs, or antennae that penetrate the water seal, induce a galvanic reaction, or otherwise compromise the effectiveness of the roof edge system, shall be eliminated or isolated to prevent problems per section 8.0 of ANSI/SPRI ES-1. Appliances should be isolated from or not attached to the roof edge system. Consult the lightning protection system manufacturer for specific attachment instructions.

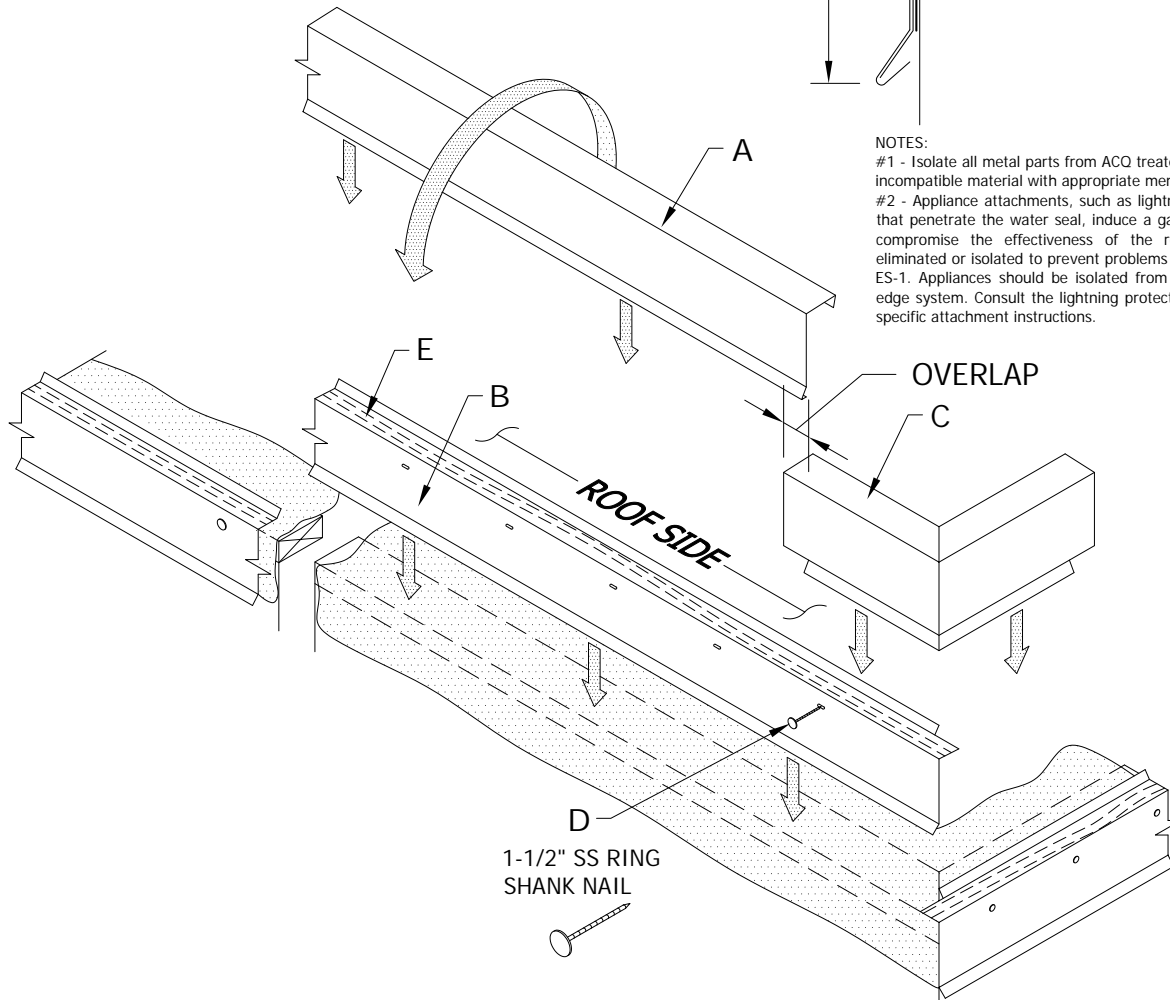

- A. Formed Fascia Cover  
10'-0" Lengths
- B. Galvanized Steel Cleat  
10'-0" Lengths
- C. Fascia Miter Cover  
(Outside Corner Shown)  
(Field Folded)

- D. 1-1/2" SS Ring Shank Nail  
at 12" o.c. (6" from ends)  
(By Installer)
- E. Non-Hardening Sealant  
Continuous Bead of Sealant  
(By Installer)

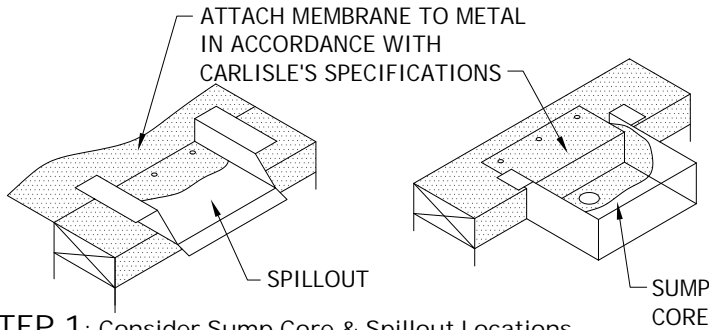

**STEP 1: Consider Sump Core & Spillout Locations**

Locate sump cores where downspouts will be located. Sumps are installed prior to the cleat. The cleat butts up to side(s) of sump core. Spillouts are installed along with the fascia lengths as required. Refer to "Spillout & Sump Core Install Guides" for more info on installation if necessary.

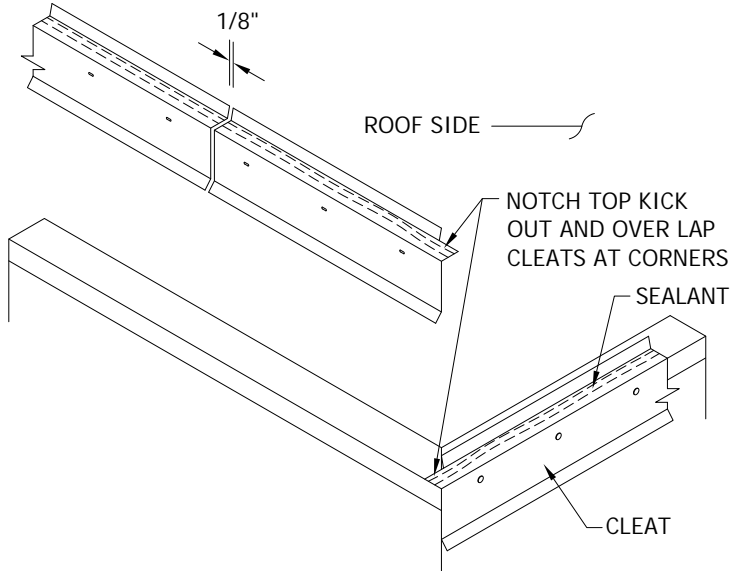

**STEP 2: Installing Cleat**

Prior to installing the cleat, ensure that all metal components have been isolated from ACQ treated lumber with appropriate membrane material. Apply a continuous bead of sealant to the bottom side of the cleat. Install cleat working away from the corners. Allow 1/8" gap between sections for thermal movement. Attach the cleat using 1-1/2" ss ring shank nails (by installer) in each pre-punched hole.

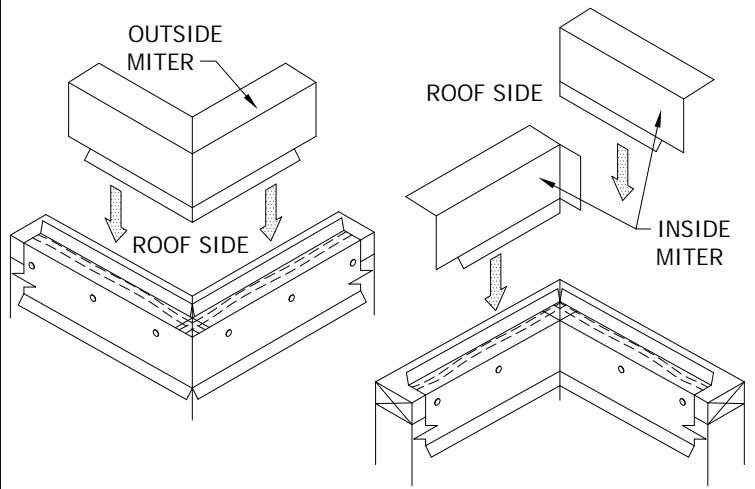
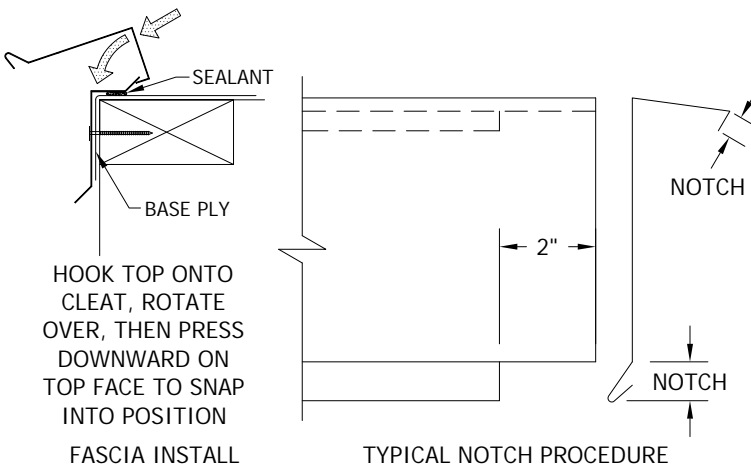

**STEP 3: Installing Fascia Miters**

Locate the miter for the appropriate corner. Notch both sides of the miters as shown. Outside miter: Fold the miter to match the building's corner angle. Center the miter over the cleat, then (see fascia install step). Inside miter: Fold the tab to match the building's corner angle. Place that leg over the cleat, then (see fascia install step). Place the opposite leg over the cleat, then (see fascia install step).

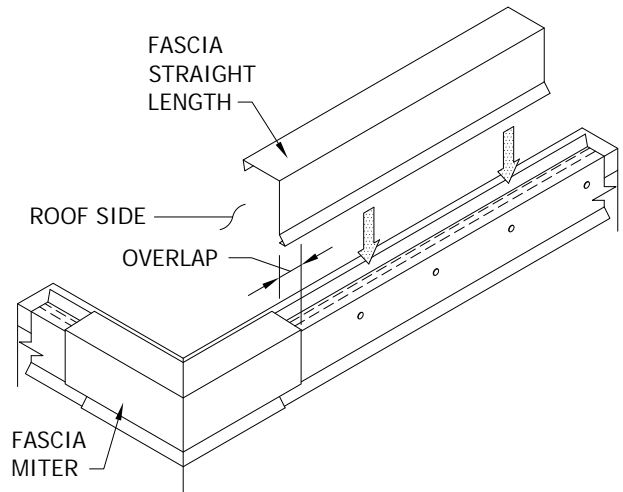

**STEP 4: Installing Fascia Straight Lengths**

Start by notching the end of the fascia opposite of the installed miter. Install the fascia (see fascia install step). Review lengths of all straight pieces prior to cutting to avoid creating relatively short sections of fascia adjacent to full length sections.

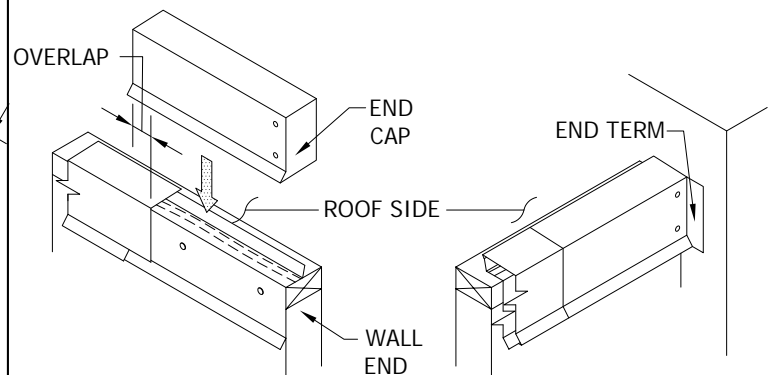

**STEP 5: Installing Fascia End Caps and End Terms**

Pop-riquet the end cap and end term inserts into place. Install the fascia end caps and end terms over the adjacent fascia's notch (see fascia install step).