



Sarnafil®

Installation Guide for Edge Grip Extruded Fascia

(For Single Ply Roofs)

ANSI/SPRI ES-1 TESTED

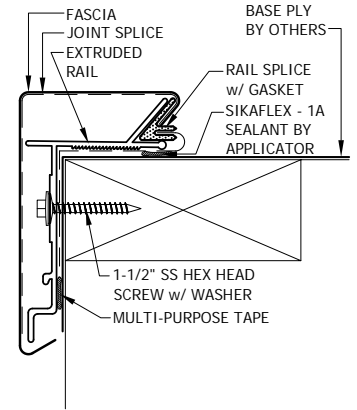

NOTES:

#1 - Isolate all metal parts from ACQ treated wood or other galvanically incompatible material with appropriate membrane material.
 #2 - Appliance attachments, such as lightning rods, signs, or antennae that penetrate the water seal, induce a galvanic reaction, or otherwise compromise the effectiveness of the roof edge system, shall be eliminated or isolated to prevent problems per section 8.0 of ANSI/SPRI ES-1. Appliances should be isolated from or not attached to the roof edge system. Consult the lightning protection system manufacturer for specific attachment instructions.

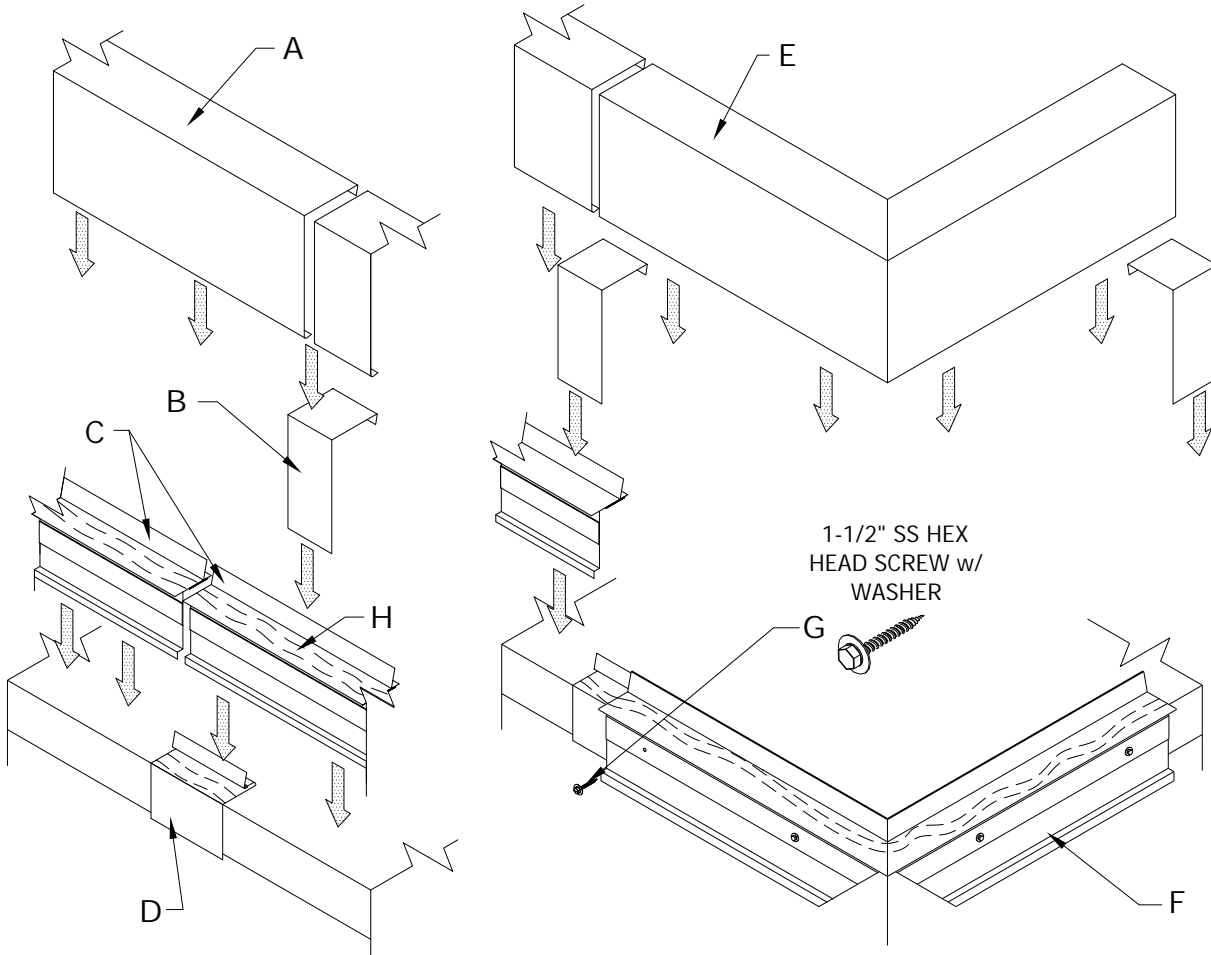

- A. Fascia Cover
10'-0" Lengths
- B. Concealed Joint Splice
4" Lengths
- C. Extruded Aluminum Rail
10'-0" Lengths
- D. Rail Splice With Gasket
6" Lengths
- E. Fascia Miter Cover
(Outside Corner Shown)

- F. Extruded Rail Corner
(Outside Corner Shown)
- G. 1-1/2" SS Hex Head Screw w/ Washer
at 12" o.c. (6" from ends)
(Included & Required)
- H. SikaFlex - 1A Sealant
Continuous Bead of Sealant
(By Installer)

SIKA SARNAFIL

100 Dan Road - Canton, MA 02021 - Phone: (781) 828-5400 - Fax: (781) 828-5365



Sarnafil®

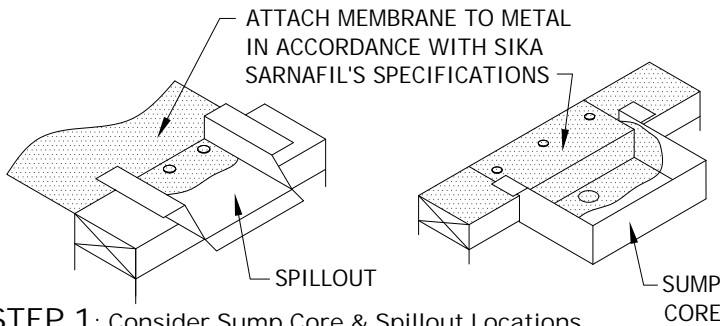

STEP 1: Consider Sump Core & Spillout Locations

Locate sump cores where downspouts will be located. Sumps are installed prior to the rail. The rail butts up to side(s) of sump core. Spillouts are installed along with the fascia lengths as required. Refer to "Spillout & Sump Core Install Guides" for more info on installation if necessary.

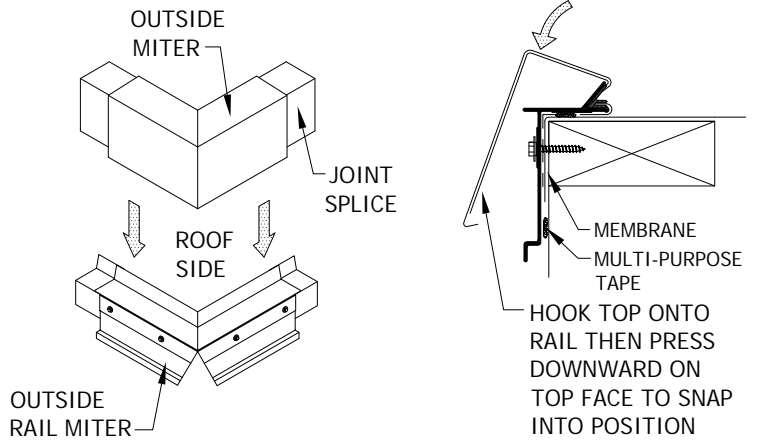

STEP 4: Installing Fascia Miters

Locate concealed joint splices in both ends of each fascia miter (as shown). Leave approximately 1/2 of the joint splice extending past the end of the miter leg. With splices inside of miter, hook the top flange of the miter onto the top flange of the rail to engage the top. Once the top of the miter has been engaged to the top of the rail, rotate the fascia outward towards the outside of the building and press down on the top flange of the fascia to snap the bottom hook onto the bottom of the rail. Make sure that the hook of the fascia has fully engaged onto the rail.

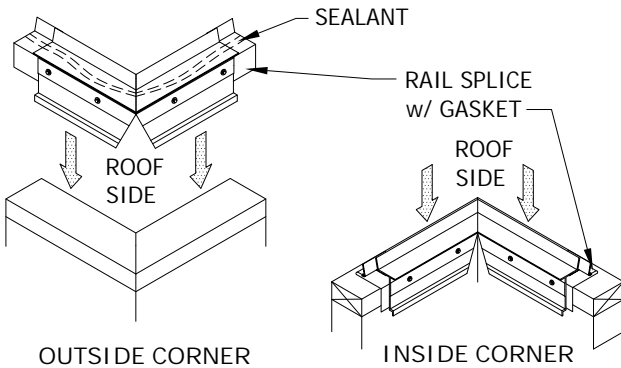

STEP 2: Installing Rail Miters

Locate rail miter for each corner. Apply a continuous bead of SikaFlex - 1A sealant to the bottom side of the rail miter. Locate a rail splice onto each end of the rail miter. Place two screws (included) in each side of the corner support.

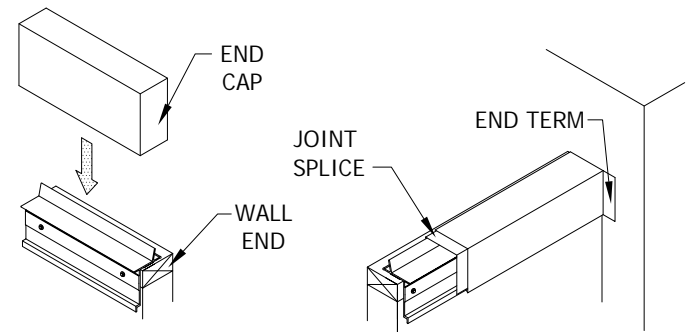

STEP 5: Installing Fascia End Caps and End Terms

Install end caps and end terms by hooking top and pressing top face downward to snap fascia into place (refer to STEP 4).

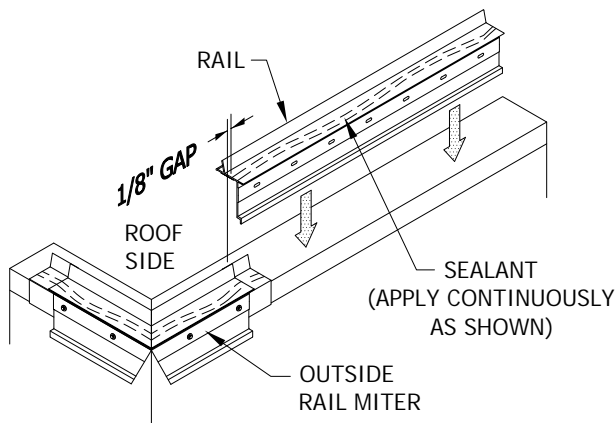

STEP 3: Installing Rail

Apply a continuous bead of SikaFlex - 1A sealant to the bottom side of the rail and apply multi-purpose tape to the back side of rail (see first page for detail view). Set the rail onto the roof edge over membrane; install a rail splice on end opposite of rail miter. Attach rail using mechanical screw fasteners (included). Install a fastener in each pre-punched hole. Allow 1/8" gap between the rail sections for thermal expansion (1/4" if temperature is below 40°F).

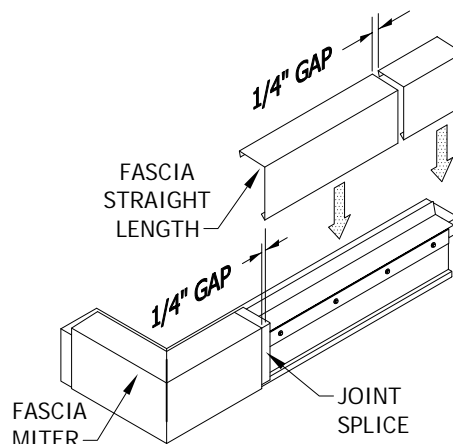

STEP 6: Installing Fascia Straight Lengths

Place a concealed joint splice in the opposite end of the installed miter or end cap. Install the fascia by hooking top and pressing top face downward to snap fascia into place. Allow 1/4" gap between the fascia sections for thermal expansion. Review lengths of all straight pieces prior to cutting to avoid creating relatively short sections of fascia adjacent to full length sections. Note: There should be a joint splice at every joint.

NOTE:
HOOK TOP TO RAIL THEN PRESS DOWNWARD ON TOP FACE TO SNAP INTO POSITION (REFER TO STEP 4)