

# PERLOK® 150 PARAPET WALL COPING



Internal metal chair drainage system eliminates caulked joints.

True welded radius, matching corners, end caps, and other accessories, are factory fabricated.

Perlok® 150 with a 16- gauge galvanized steel cleat is Approved for up to an FM 1-180 Wind Storm Rating and has our 20-Year, 150 mph Warranty

Tested, certified, and approved to withstand the peeling effects of strong winds

Pre-punched holes and supplied fasteners for proper attachment and fast installation.

*Perlok® 150 utilizes a metal chair which functions as both a gutter chair with it's raised ribs and as an internal splice plate in the same color and finish as the coping cap.*

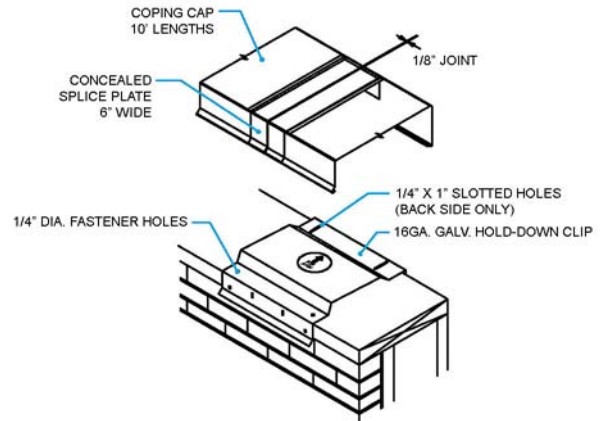
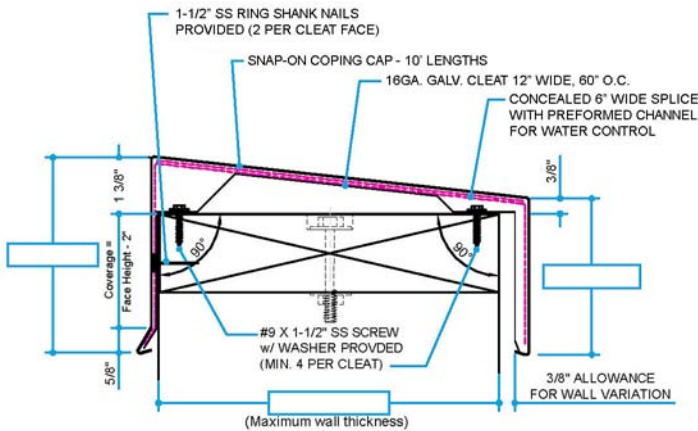

Standard Sizes	Material	Gauge	Finishes
Wall Sizes - 6" - 32"	Aluminum Galvanized Steel	Standard is .050" & .063" Standard is 24 Gauge	Mill Finish
Standard Leg Size - 4" Minimum Leg Size - 2.125" Maximum Face Size - 12"	Copper & Stainless Steel By Request	Other Metal Thicknesses By Request	Manufacturer's Standard Kynar 500® Colors
Nominal Miter Leg Lengths 6" - 17" Wall - 24" Nominal 17" - 32" Wall - Wall Width + 6"			Custom or Exotic Kynar 500® Post-Finished Colors
			Clear Anodize Bronze Anodize



**DERBIGUM®**  
MAKING BUILDINGS SMART

PERFORMANCE Roof Systems, Inc.  
4800 Blue Parkway  
Kansas City, MO 64130  
Phone - 800.727.9872 - Fax 816.924.1542  
E-mail : info@derbigum.com - WWW.DERBIGUM.COM

## Perlok® 150 Coping

### **SPECIFICATIONS** *(short form)*

The coping cap shall be the Perlok® 150 coping system as provided by the Performance Roof Systems. The coping cap shall be formed as indicated with allowance for expansion and contraction. The standard support cleat shall be a 16 Ga. galvanized steel cleat with pre-slotted fastener holes. A 6" wide concealed splice plate with raised ribs on the top surface to channel water shall be installed at coping joints. Installation shall conform to Manufacturer's written instructions.

### **DESCRIPTION**

#### *Application:*

The product is a metal coping with hold down cleats and metal drain chairs for capping most any parapet. Standard coping is formed from .063" (1.60 mm) or .050" (1.25 mm) aluminum; 24 Ga. Galv. Steel with Kynar 500® coating; custom metal by request. Standard length is 10' with standard corners having 24" nominal length. Cleats are 16 Ga. Galvanized steel. Chairs are metal in the same color and finish as the coping cap. Standard widths in 1" (25mm) increments for walls between 6" (152mm) and 32" (812mm) in width. See chart. Face and back leg are 4" (102mm) nominal length with tested approvals up to 6" (152mm). Custom sizes by request. Your Performance Roof Systems Representative will be happy to discuss your special design requirements.

### **INSTALLATION PROCEDURES**

**NOTE:** *This is a general outline only.*

*Please refer to our full installation guide for additional specific detail.*

#### **Preparation:**

The substrate should be flat and level from front to back. Shim areas not level.

#### **Procedure:**

The first cleat/chair set should be installed with the center line at nominal (see chart on front page) 24" (300mm) from the outside wall of an outside corner, 24" (300mm) from the inside wall of an inside corner and 24" (300mm) from the end of a wall. Install cleats/chairs sets at all corners and ends first, then work along the wall to the center locating sets every five feet on center. Most walls are not equally divided

by five feet. Therefore, at the middle of a run, adjust the location to fit a short coping length. This procedure will provide a symmetrical appearance of the installed coping. Install metal gutter chair/concealed joint covers at joint locations. Hook coping face leg over the cleat face (front) leg and swing over the top. Snap the roof side (back) leg by pressing firmly down on the back edge directly over the cleat chair sets. Allow 1/8" (3mm) gap, 1/4" (6mm) in colder weather, at each joint.

### **FINISHES**

- Natural mill aluminum
- Pre-coat Kynar 500® — from the manufacturer's standard color chart
- Post-coat Kynar 500® — industry standard two coat colors
- Non-standard Kynar 500® — colors requiring multiple coatings or protective clear coats
- Anodized aluminum – clear, bronze and black

### **GUARANTEE**

#### **A. Manufacturer's Standard**

**Warranty:** Materials shall be free of defects in material and workmanship for five years after shipment. If, after inspection, the manufacturer agrees that the materials supplied by them are defective, the manufacturer shall at their option repair or replace them.

#### **B. Special 20-Year, 150 mph Warranty:**

Manufacturer shall guarantee that a standard size roof edge system, when installed per manufacturer's instructions, will not blow off, leak, or cause membrane failure, even in wind conditions up to 150 mph, or the manufacturer shall replace or repair its materials.

#### **C. Decorative Finish Warranty** *(consult manufacturer).*

### **QUALITY ASSURANCE**

Perlok® 150 coping is listed in the current Factory Mutual Research Corporation Approval Guide approved for Windstorm ratings up to FM 1-180 depending upon wall width, cleat spacing, and gauge of

cap. Consult FMRC Approval Guide or Performance Roof Systems for other conditions. High performance coping system shall be certified by the coping manufacturer to meet ANSI/SPRI ES-1 Test Method RE-3 for coping. The Perlok® 150 coping system has been tested simultaneously on the horizontal and vertical surfaces and has exceeded design wind pressure as calculated in accordance with the current edition of ANSI/SPRI ES-1 "Wind Design Standard for Edge Systems used with Low Slope Roofing Systems".

### **TECHNICAL SERVICES**

Engineering and shop drawings are available from the factory. Product samples, detail sheets, color chips and color charts are ready for your submittal package. For personal assistance with questions or submittals, contact your local representative or call Performance Roof Systems.

## **Performance Roof Systems**

4800 Blue Parkway, Kansas City, MO 64130 • Phone (800) 727-9872 • Fax (816) 924-1542 • [www.derbigum.com](http://www.derbigum.com)