



Installation Guide for SopraCap Coping

ANSI-SPRI ES-1 TESTED

Straight Parapets 6" through 32" Wide

Also included: Installation Guides for

Radius Parapets 6" through 32" Wide

Vaulted Parapets 6" through 32" Wide

Special Wall Conditions 6" through 32" Wide

NOTES:

#1 - Isolate all metal parts from ACQ treated wood or other galvanically incompatible material with appropriate membrane material.

#2 - Appliance attachments, such as lightning rods, signs, or antennae that penetrate the water seal, induce a galvanic reaction, or otherwise compromise the effectiveness of the roof edge system, shall be eliminated or isolated to prevent problems per section 8.0 of ANSI/SPRI ES-1. It is recommended that appliances be isolated from or not attached to the roof edge system. Consult the lightning protection system manufacturer for specific attachment instructions.

Installation Guide Index

General Information

Coping Diagrams

Straight Parapet Installation

Radius Parapet Installation

Vaulted Parapet Installation

Special Condition Installation

Soprema, Inc.

310 Quadral Drive - Wadsworth, OH 44281 - Phone: (800) 356-3521 - Fax: (330) 334-4289

DO NOT USE SEALANT
AT JOINT SPLICES

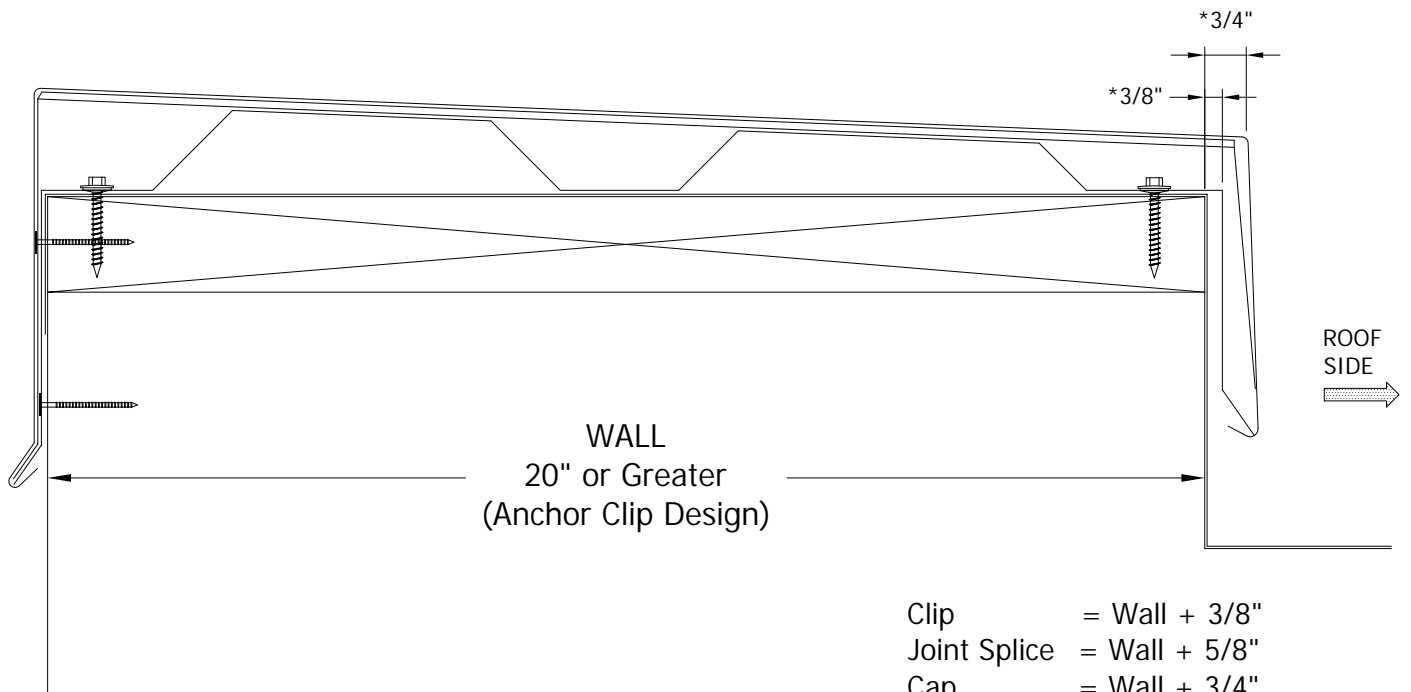
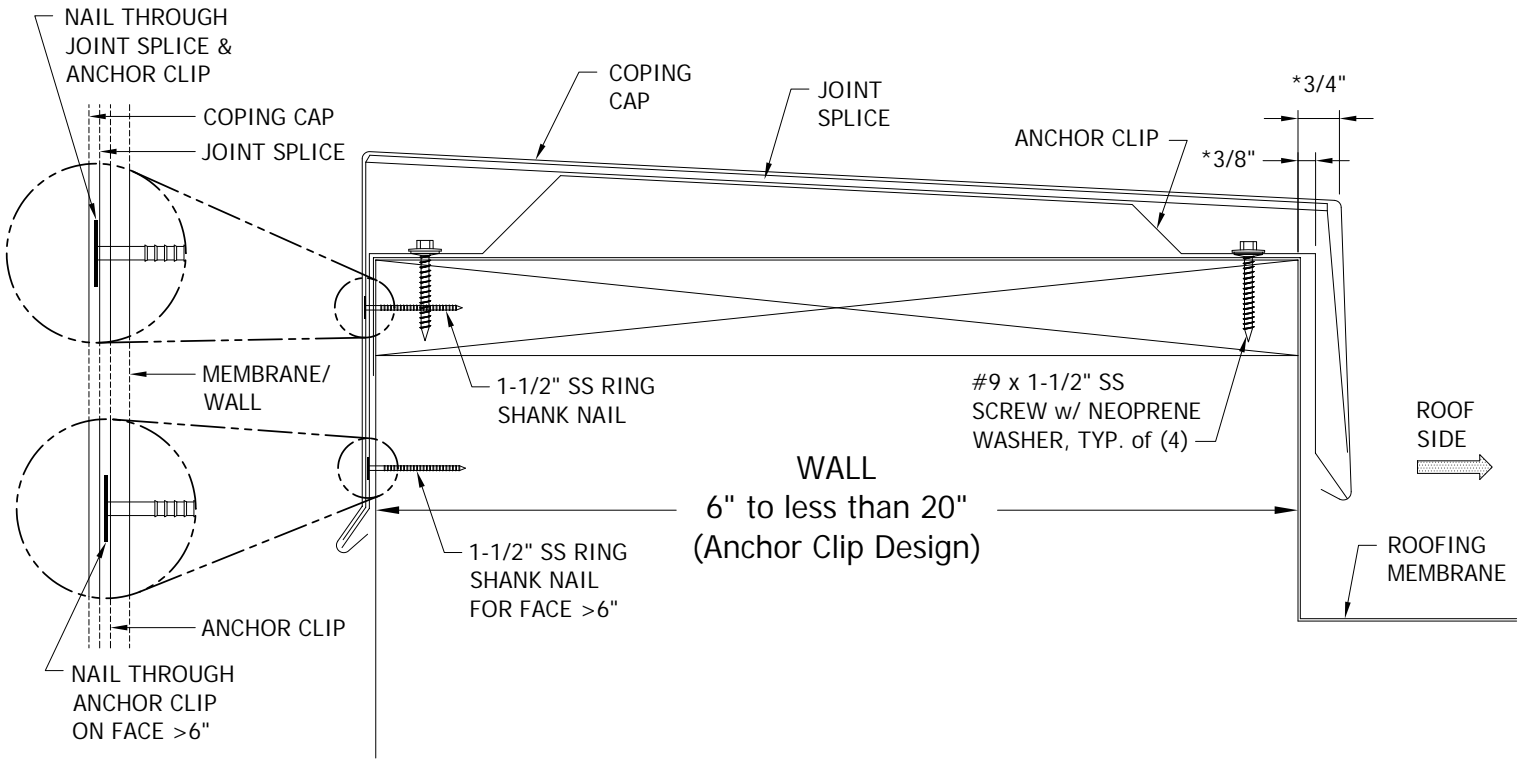

Clip = Wall + 3/8"

Joint Splice = Wall + 5/8"

Cap = Wall + 3/4"

*DIMENSION WILL VARY WITH WALL WIDTH VARIATION

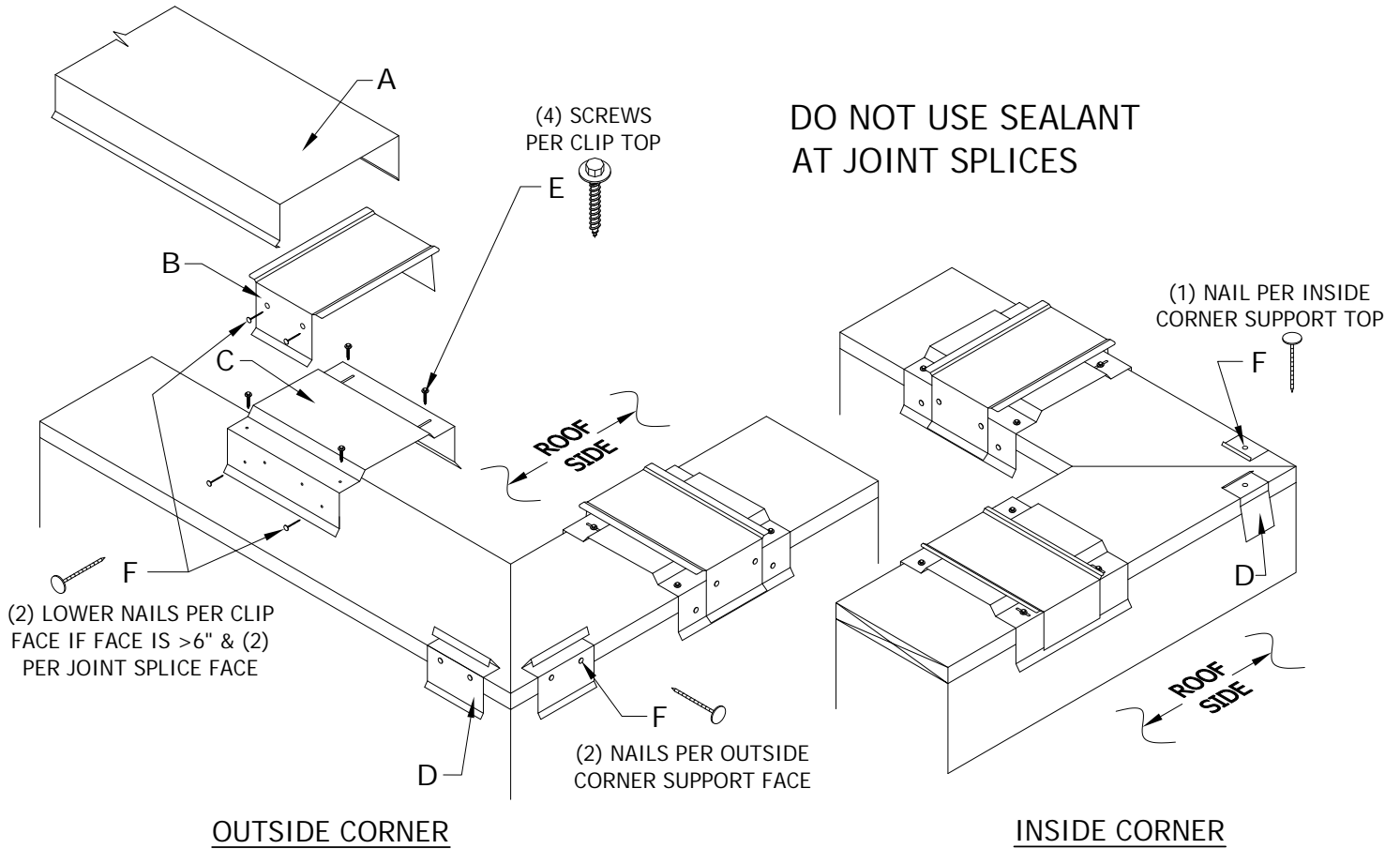

- A. Formed Coping Cap
10'-0" Lengths
- B. 6" Wide Concealed Joint Splice
One (1) at Each Clip Location
- C. 12" Wide Galv. Anchor Clip
6" ≤ Wall Width < 17" Install @ 60" on center
17" ≤ Wall Width ≤ 32" Install @ 40" on center
- D. Corner Supports (Inside & Outside)
Used to Support Outside and Inside Miters

- E. #9 x 1-1/2" SS Screw w/ Neoprene Washer
Four (4) Per Clip Top
(Provided & Required by Manufacturer)
- F. 1-1/2" SS Ring Shank Nail
Two (2) Per Clip Face if Face is >6"
Two (2) Per Joint Splice Face
Two (2) Per Outside Corner Support Face
One (1) Per Inside Corner Support Top
(Provided & Required by Manufacturer)

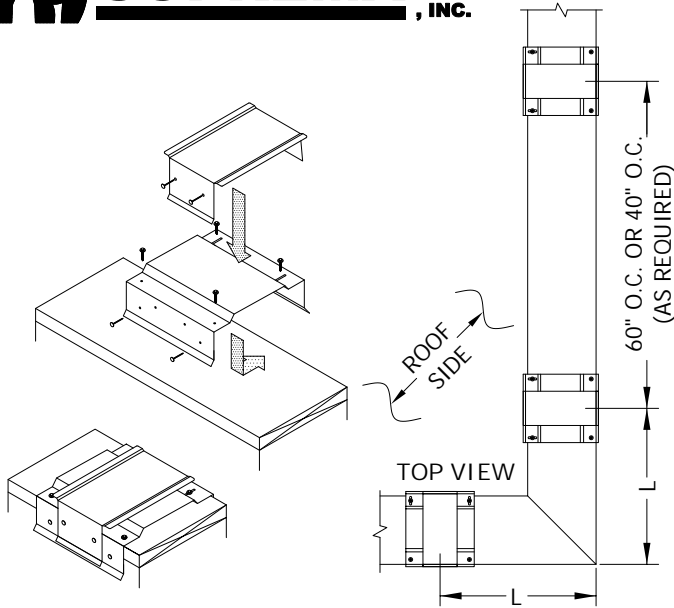

L=23 1/4" - for wall widths ≤ 16" wide
 L=29 1/4" - for wall widths > 16" and ≤ 23" wide
 L=custom for wall widths > 23" wide

STEP 1: Installing Anchor Clips at Corners & Along the Parapet

Locate anchor clips as shown. Pull clips snugly against the outside face. Place four (4) screw fasteners in the top of the clip with fasteners centered in slotted holes. Place two (2) ss ring shank nails in the clip face if face is >6". Position the joint splice over the center of the clip and install as shown using two (2) ss ring shank nails thru aligning holes. Joint splices should be installed at ALL clip locations.

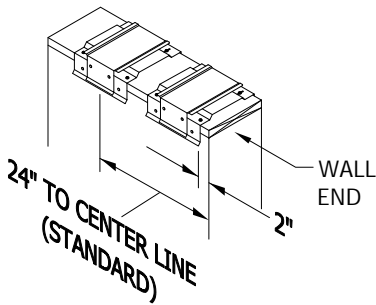

STEP 2: Installing Anchor Clips at Wall Ends

Install the first anchor clip approximately 2" from the wall end as shown. Install the second anchor clip 24" on center from the wall end. (If end cap leg is other than 24" adjust clip accordingly.)

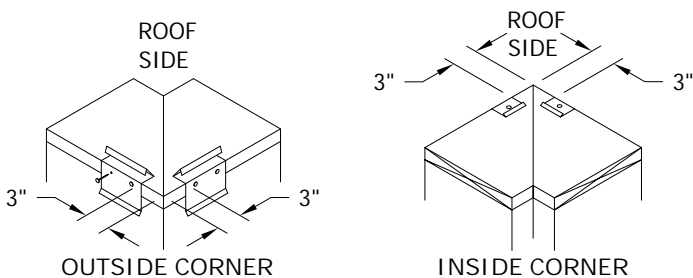

STEP 3: Installing Corner Support Clips

Two (2) corner support clips are to be placed at all corners to support the cap. Secure clips using 1-1/2" ss ring shank nails. Set each clip away from the corner approximately 3".

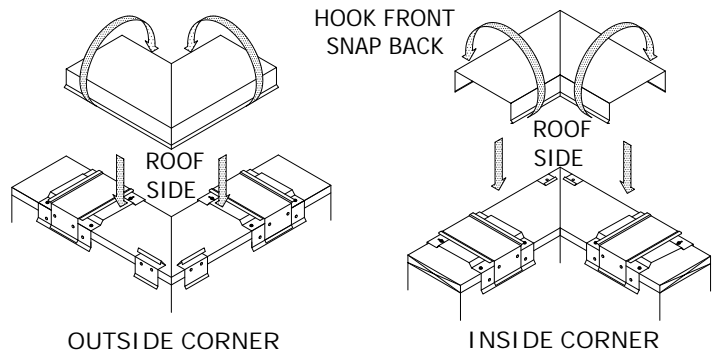

STEP 4: Installing Coping Miters

Hook the face of the coping miter over the outside face leg of the clips, rotate the coping miter over the top of the clips and snap the roof side leg by pressing down.

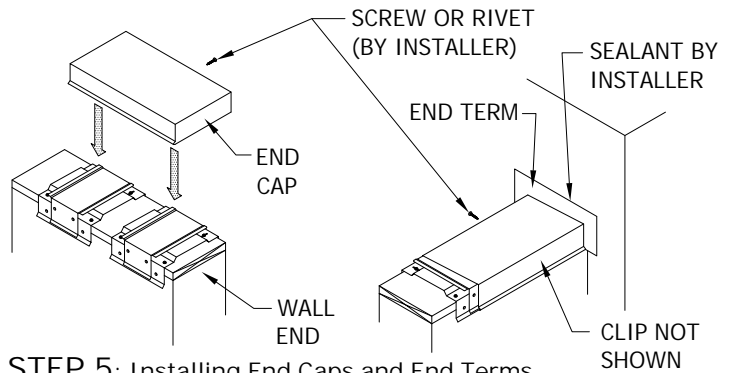

STEP 5: Installing End Caps and End Terms

Install end caps and end terms by hooking face and snapping back into place. End caps must be restrained from moving by securing the end cap to the clip using a stainless steel screw or rivet (by installer) through the roof side leg of the end cap. End terms should be restrained similarly if no fasteners are previously installed in the end term wall flange.

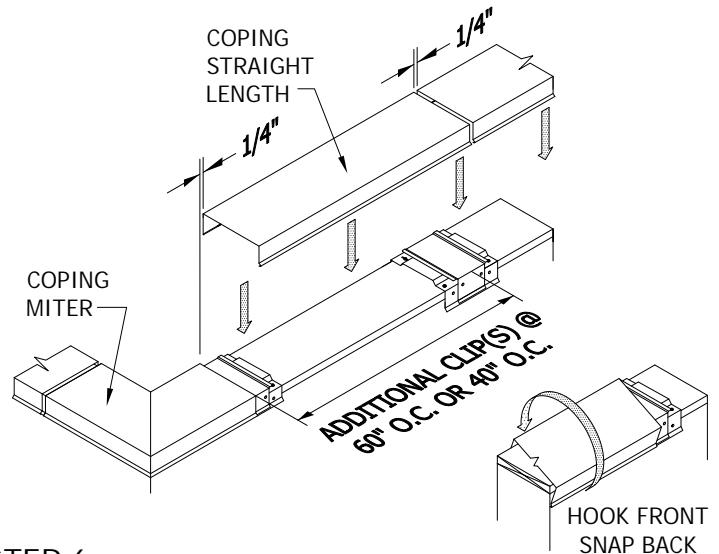

STEP 6: Installing Coping Straight Lengths

Begin installing from the corners and ends working inward to the center. Allow a 1/4" gap between the coping sections for thermal expansion. Lengths of all straight pieces should be considered prior to cutting to avoid creating relatively short sections of cap adjacent to full length sections. There should be an anchor clip and joint splice at least every 60" O.C. (40" O.C. when wall is 17"-32" wide) and at every joint. Every fifth 10-foot section of coping should be secured to the clip using a single stainless steel screw or rivet (same procedure as STEP 5) to isolate movement within a containment zone.

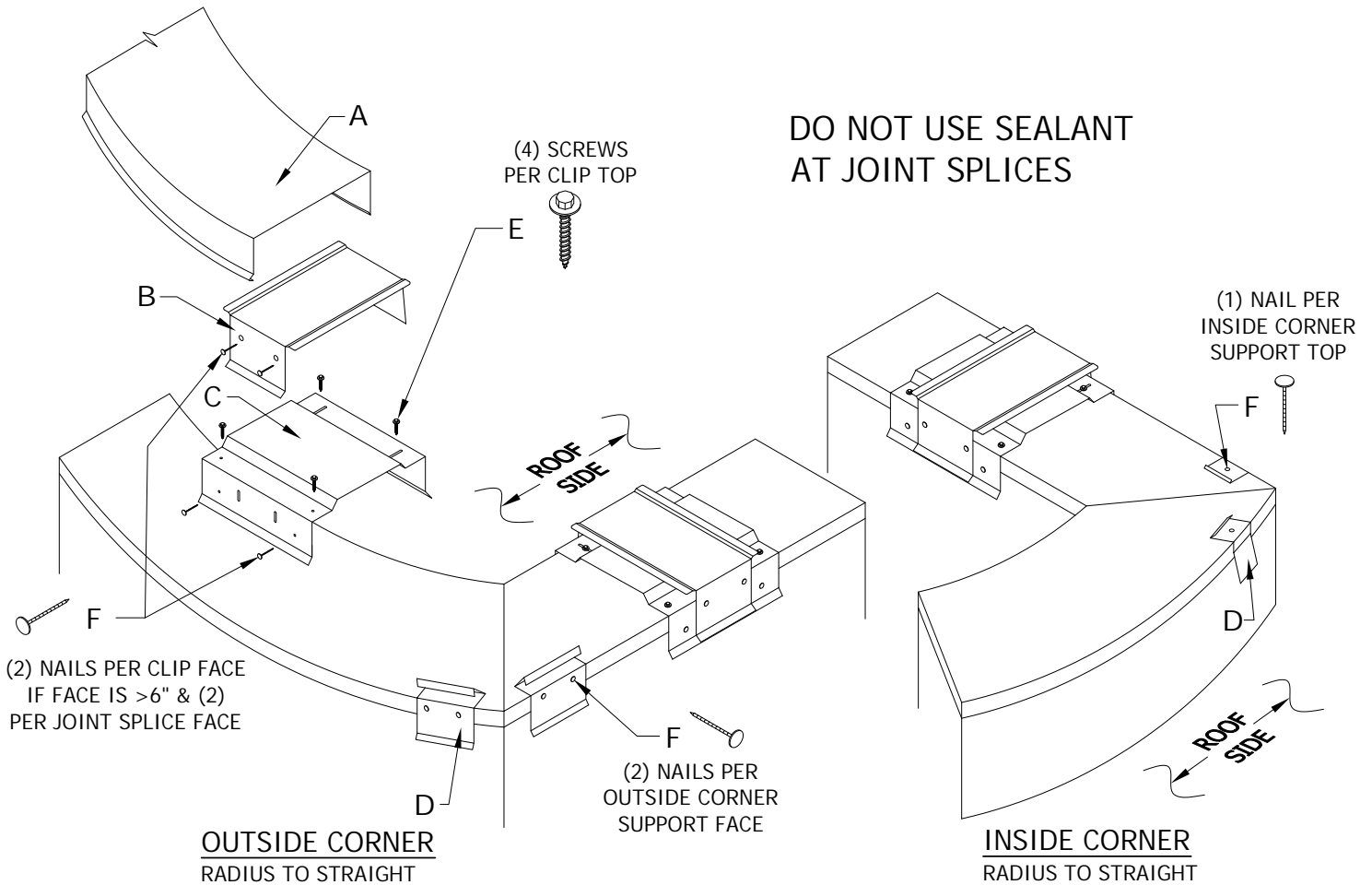

- A. Radius Coping Cap
60" Lengths Typ. (Lengths May Vary)
- B. 6" Wide Concealed Joint Splice
One (1) at Each Clip Location
- C. 12" or 6" Wide Galv. Steel Anchor Clip
6" ≤ Wall Width < 17" Install @ 60" on center
17" ≤ Wall Width ≤ 32" Install @ 30" on center
- D. Corner Supports (Inside & Outside)
Used to Support Outside and Inside Corners

- E. #9 x 1-1/2" SS Screw w/ Neoprene Washer
Four (4) Per Clip Top
(Provided & Required by Manufacturer)
- F. 1-1/2" SS Ring Shank Nail
Two (2) Per Clip Face if Face is >6"
Two (2) Per Joint Splice Face
Two (2) Per Outside Corner Support Face
One (1) Per Inside Corner Support Top
(Provided & Required by Manufacturer)

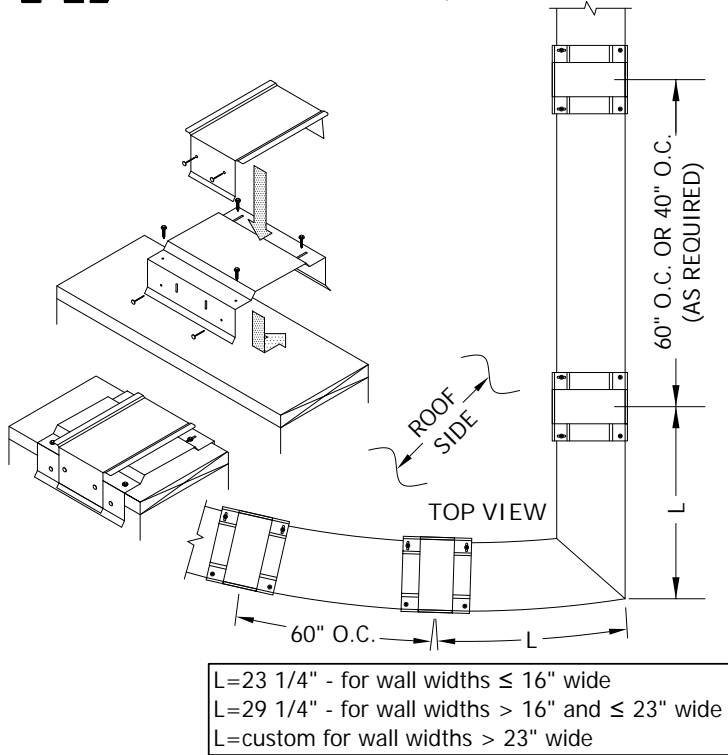

STEP 1: Installing Anchor Clips at Corners & Along the Parapet
 Locate anchor clips as shown. Pull clips snugly against the outside face. Place four (4) screw fasteners in the top of the clip with fasteners centered in slotted holes. Place two (2) ss ring shank nails in the clip face if face is >6". Position the joint splice over the center of the clip and install as shown using two (2) ss ring shank nails thru aligning holes. Joint splices should exist at ALL clip locations.

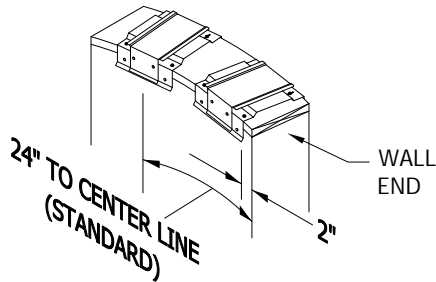

STEP 2: Installing Anchor Clips at Wall Ends
 Install the first anchor clip approximately 2" from the wall end as shown. Install the second anchor clip 24" on center from the wall end. (If end cap leg is other than 24" adjust clip accordingly.)

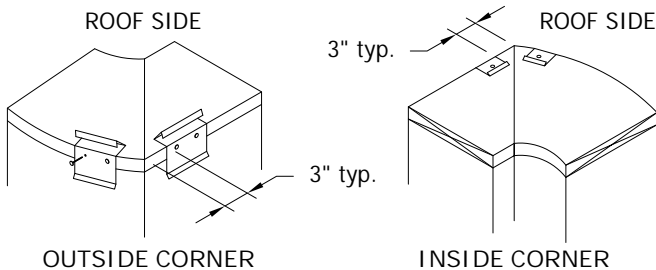

STEP 3: Installing Corner Support Clips
 Two (2) corner support clips are to be placed at all corners to support the cap. Secure clips using 1-1/2" ss ring shank nails. Set each clip away from the corner approximately 3".

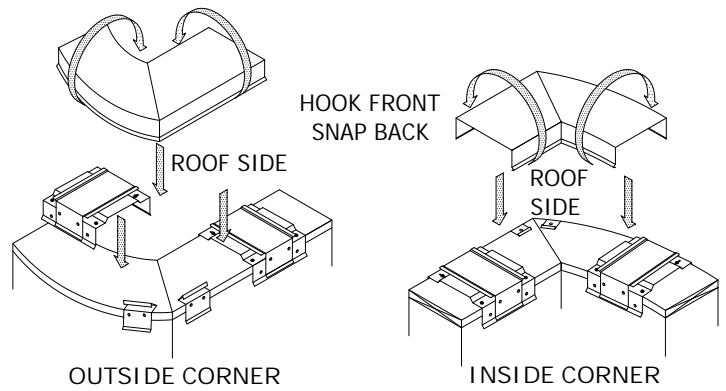

STEP 4: Installing Radius to Straight Coping Miters
 Hook the face of the coping miter over the outside face leg of the clips, rotate the coping miter over the top of the clips and snap the roof side leg by pressing down.

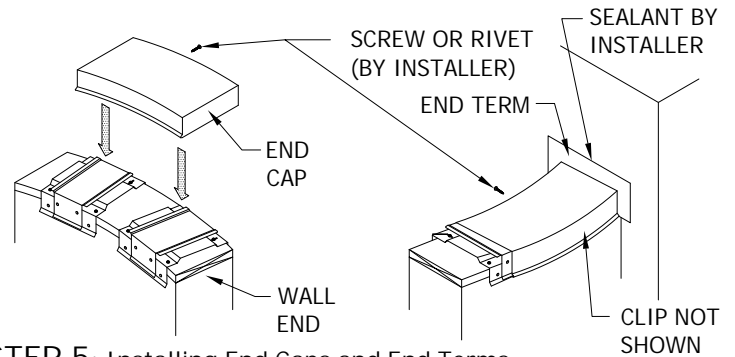

STEP 5: Installing End Caps and End Terms
 Install end caps and end terms by hooking face and snapping back into place. End caps must be restrained from moving by securing the end cap to the clip using a stainless steel screw or rivet (by installer) through the roof side leg of the end cap. End terms should be restrained similarly if no fasteners are previously installed in the end term wall flange.

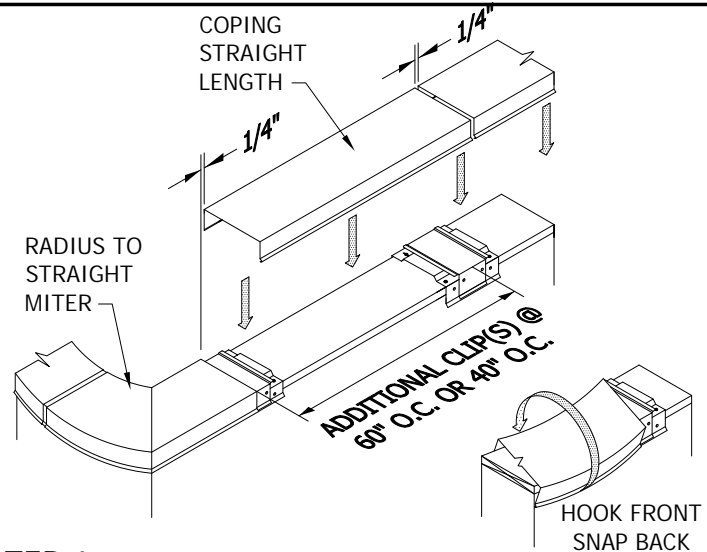

STEP 6: Installing Radius Coping Lengths
 Begin installing from the corners and ends working inward to the center. Allow a 1/4" gap between the coping sections for thermal expansion. Lengths of all radius pieces should be considered prior to cutting to avoid creating relatively short sections of cap adjacent to full length sections. There should be an anchor clip and joint splice at least every 60" O.C. (clip spacing may vary) and at every joint. Every fifth 60" section of coping should be secured to the clip using a single stainless steel screw or rivet (same procedure as STEP 5) to isolate movement within a containment zone.

VAULTED PARAPET INSTALLATION

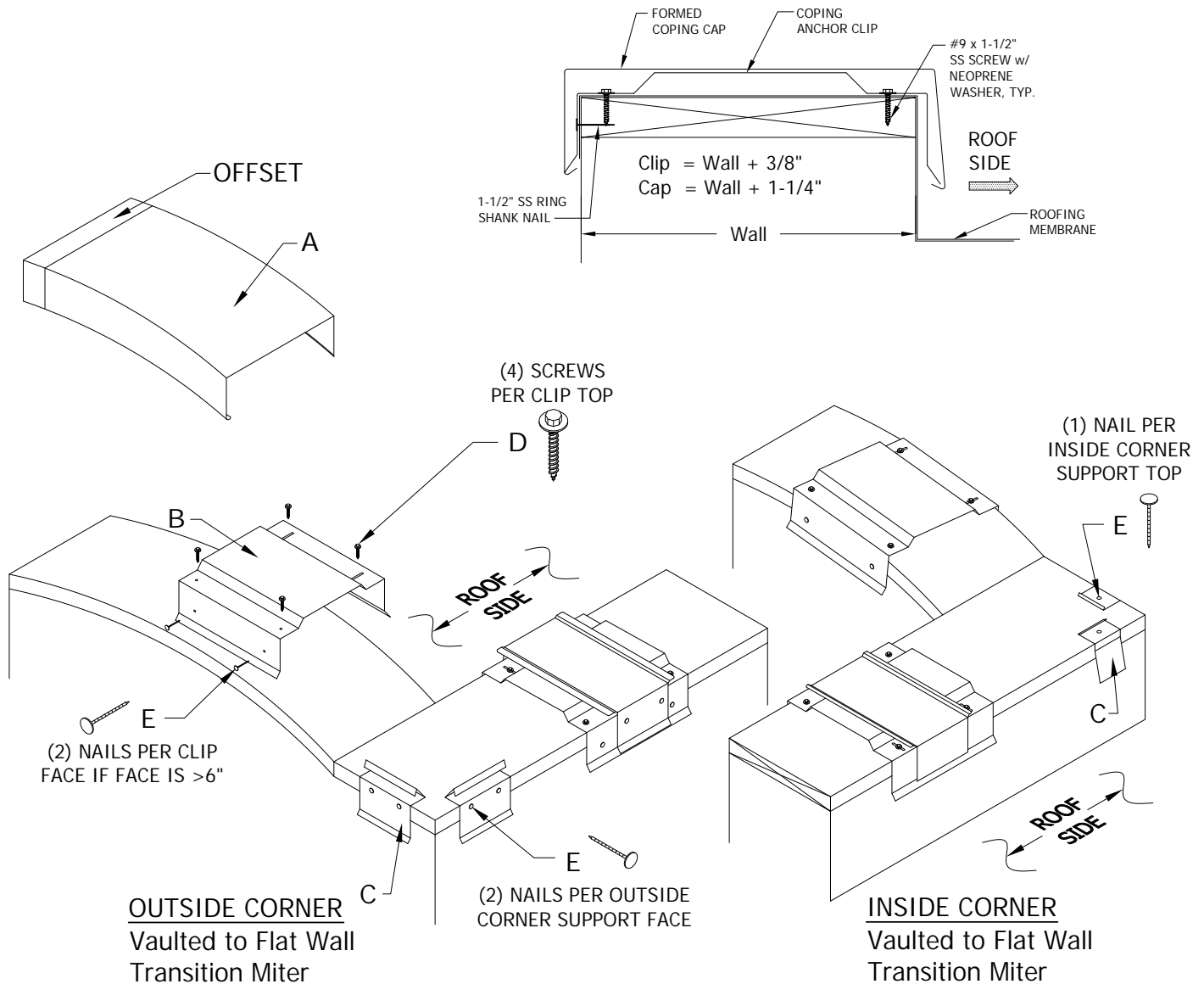

- A. Vaulted Coping Cap
60" Lengths Typ. (Lengths May Vary)
- B. Galvanized Steel Anchor Clip
6" or 12" Wide at 60" On Center Typ.
(Clip Spacing May Vary)
- C. Corner Supports (Inside & Outside)
Used to Support Outside and Inside Corners

- D. #9 x 1-1/2" SS Screw w/ Neoprene Washer
Four (4) Per Clip Top
(Provided & Required by Manufacturer)
- E. 1-1/2" SS Ring Shank Nail
Two (2) Per Clip Face if Face is >6"
Two (2) Per Outside Corner Support Face
One (1) Per Inside Corner Support Top
(Provided & Required by Manufacturer)

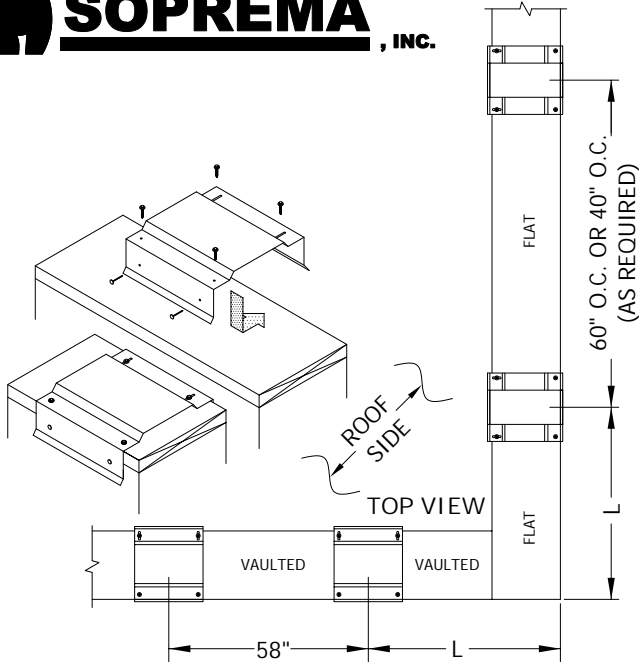

L=23 1/4" - for wall widths ≤ 16" wide
 L=29 1/4" - for wall widths > 16" and ≤ 23" wide
 L=custom for wall widths > 23" wide

STEP 1: Installing Anchor Clips at Corners & Along the Parapet

Locate anchor clips as shown. Pull clips snugly against the outside face. Place four (4) screw fasteners in the top of the clip with fasteners centered in slotted holes. Place two (2) ss ring shank nail in the clip face if face is >6". DO NOT place anchor clip at joint locations.

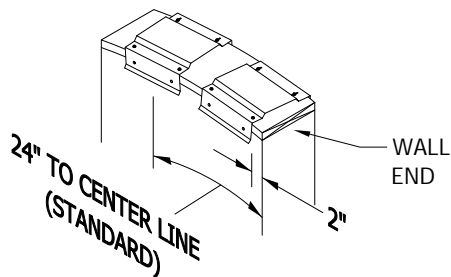

STEP 2: Installing Anchor Clips at Wall Ends

Install the first anchor clip approximately 2" from the wall end as shown. Install the second anchor clip 24" on center from the wall end. DO NOT place second clip at joint location. (If end cap leg is other than 24" adjust clip accordingly.)

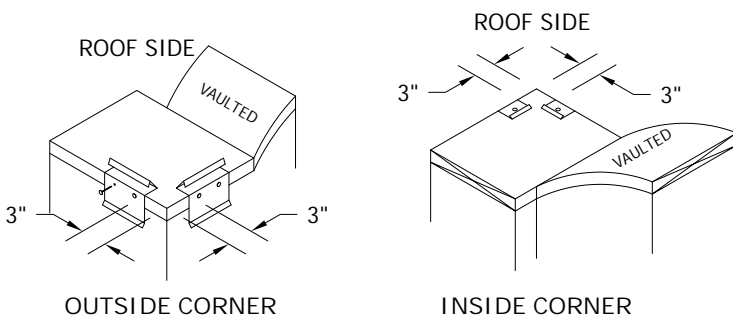

STEP 3: Installing Corner Support Clips

Two (2) corner support clips are to be placed at all corners to support the cap. Secure clips using 1-1/2" ss ring shank nails. Set each clip away from the corner approximately 3".

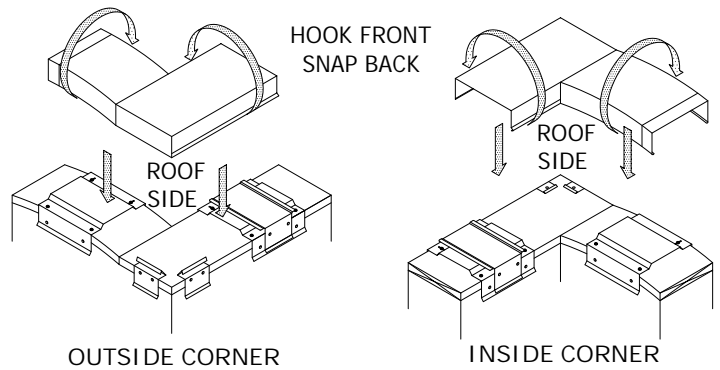

STEP 4: Installing Coping Miters

Hook the face of the coping miter over the outside face leg of the clips, rotate the coping miter over the top of the clips and snap the roof side leg by pressing down.

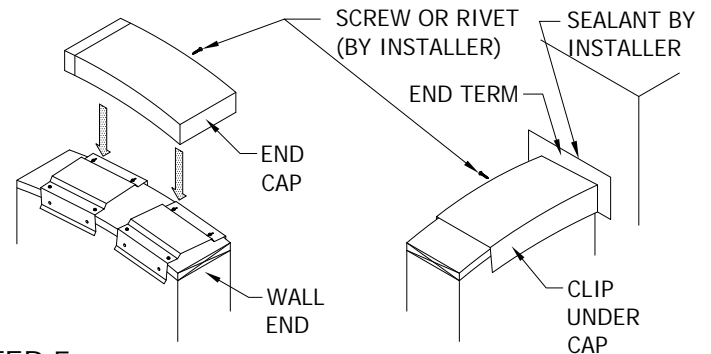

STEP 5: Installing End Caps and End Terms

Install end caps and end terms by hooking face and snapping back into place. End caps must be restrained from moving by securing the end cap to the clip using a stainless steel screw or rivet (by installer) through the roof side leg of the end cap. End terms should be restrained similarly if no fasteners are previously installed in the end term wall flange.

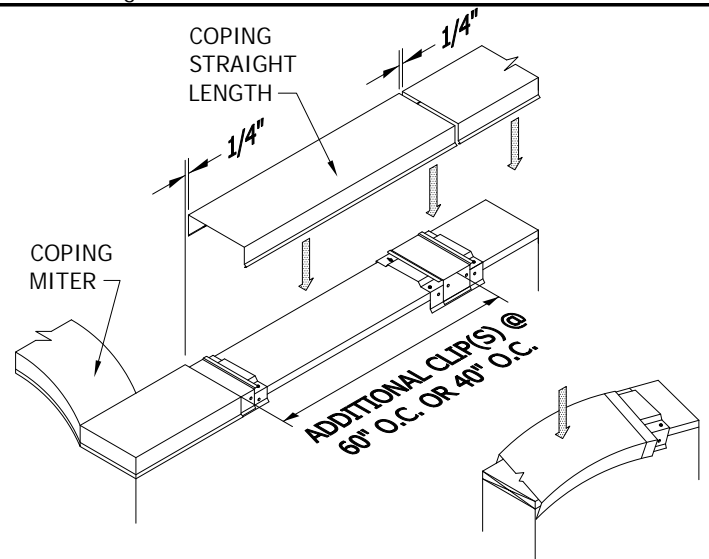

STEP 6: Installing Vaulted Coping Lengths

Begin installing from the corners and ends working inward to the center. Allow a 1/4" gap between the coping sections for thermal expansion. Lengths of all vaulted pieces should be considered prior to cutting to avoid creating relatively short sections of cap adjacent to full length sections. There should be an anchor clip at least every 60" O.C. (Clip spacing may vary). Every fifth 60" section of coping should be secured to the clip using a single stainless steel screw or rivet (same procedure as STEP 5) to isolate movement within a containment zone.

SPECIAL CONDITION INSTALLATION

CLEATS ONLY SHOW FOR CLARITY. SEE PAGE 3 FOR SPLICE AND CAP DRAWINGS.

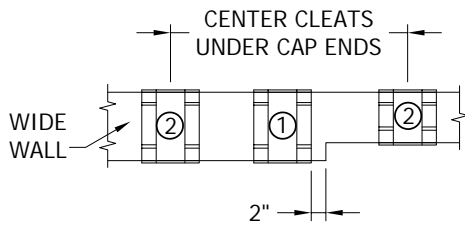

INLINE TRANSITION

NOTE: Instructions are for face leg and back leg offsets.

STEPS:

1. Install cleat ① 2" from offset, use only if wide wall cap leg length is longer than 20".
2. Install cleats ② centered under cap ends.

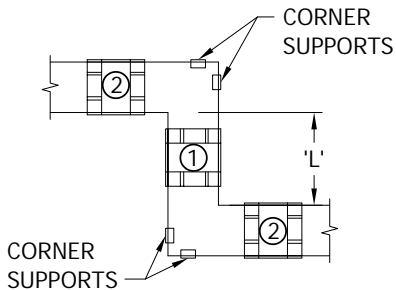

'Z' MITER

NOTE: Instructions work for face leg on either side.

STEPS:

1. Install cleat ① only if 'L' is longer than 14".
2. Install cleats ② centered under cap ends.
3. Install appropriate corner supports in designated areas.

EXAMPLE 1

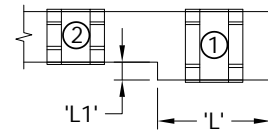

EXAMPLE 2

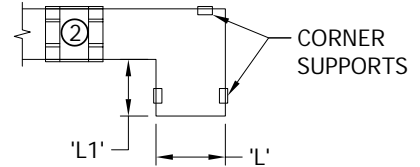

PIER END TRANSITION

NOTE: Instructions are for face leg and back leg offsets.

STEPS:

1. Install cleat ① only if 'L' is longer than 12".
2. For 'L1' cleats and corner supports, see below.
3. Install cleats ② centered under cap ends.

'L1' > 12"	'L1' < 12"
Install corner supports as shown in EXAMPLE 2	Install cleat as shown in EXAMPLE 1

EXAMPLE 1

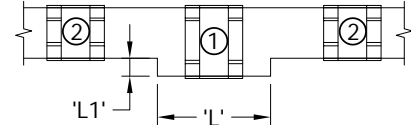

EXAMPLE 2

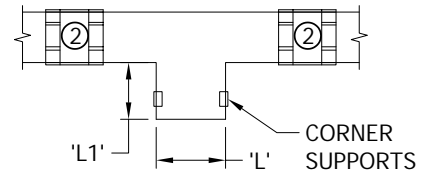

PIER INLINE TRANSITION

NOTE: Instructions are for face leg and back leg offsets.

STEPS:

1. Install cleat ① only if 'L' is longer than 12".
2. For 'L1' procedures see table below.
3. Install cleats ② centered under cap ends.

'L1' > 12"	'L1' < 12"
Install corner supports as shown in EXAMPLE 2	Install cleat as shown in EXAMPLE 1