

Installation Guide for VersiTrim 3000

ANSI/SPRI ES-1 TESTED

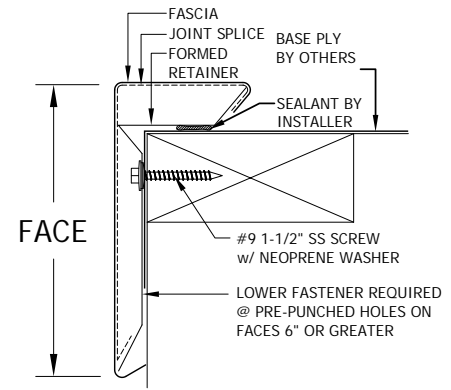

NOTES:

#1 - Isolate all metal parts from ACO treated wood or other galvanically incompatible material with appropriate membrane material.

#2 - Appliance attachments, such as lightning rods, signs, or antennae that penetrate the water seal, induce a galvanic reaction, or otherwise compromise the effectiveness of the roof edge system, shall be eliminated or isolated to prevent problems per section 8.0 of ANSI/SPRI ES-1. Appliances should be isolated from or not attached to the roof edge system. Consult the lightning protection system manufacturer for specific attachment instructions.

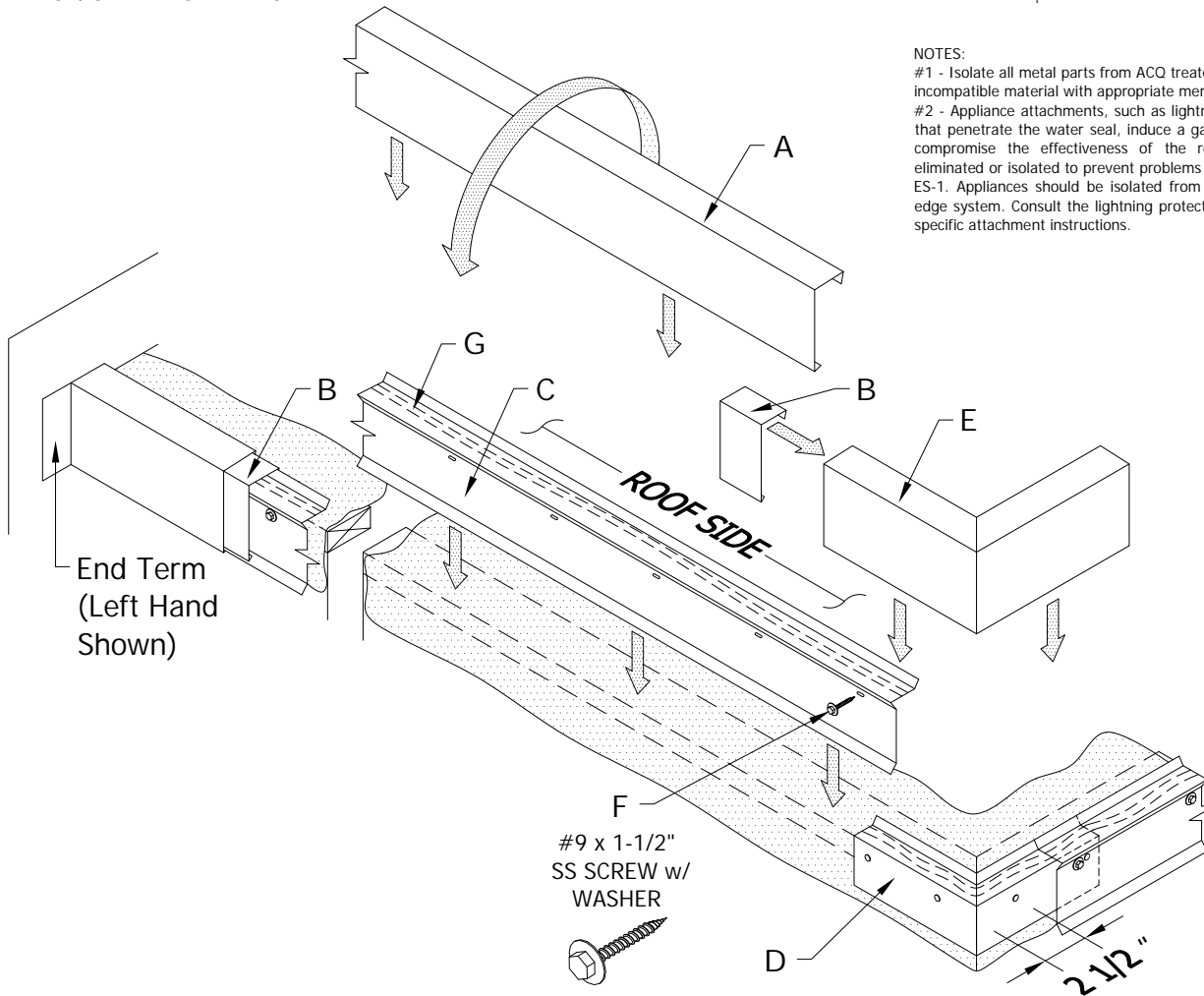

- A. Formed Fascia Cover
10'-0" Lengths
- B. Concealed Joint Splice
4" Lengths
- C. Formed Retainer
10'-0" Lengths
- D. Corner Support (Outside)
At All Inside and Outside Corners
- E. Fascia Miter Cover
(Outside Corner Shown)

- F. #9 x 1-1/2" SS Screw w/ Neoprene Washer
at 12" o.c. (6" from ends)
Four (4) at All Corner Supports
(Included & Required)
Lower Fastener Required @ Pre-Punched Holes
For Faces 6" or Greater
- G. Non-Hardening Sealant
Continuous Bead of Sealant
(By Installer)

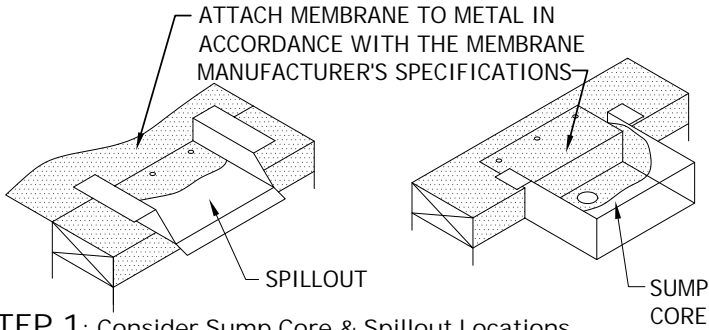

STEP 1: Consider Sump Core & Spillout Locations

Locate sump cores where downspouts will be located. Sumps are installed prior to the retainer. The retainer butts up to side(s) of sump core. Spillouts are installed along with the fascia lengths as required. Refer to "Spillout & Sump Core Install Guides" for more info on installation if necessary.

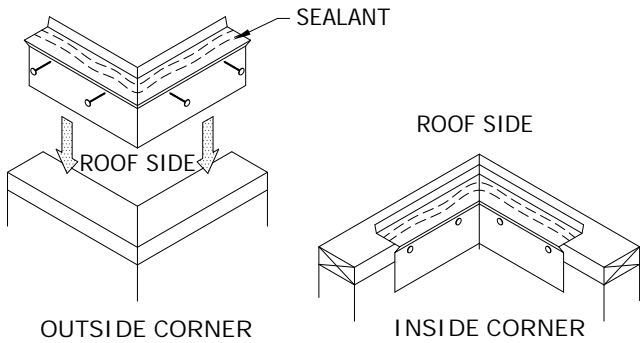

STEP 2: Installing Corner Supports

Locate corner supports for each corner. Apply a continuous bead of the roofing manufacturer's sealant to the bottom side of the corner support. Place two nails (provided by installer) in each side of the corner support as shown.

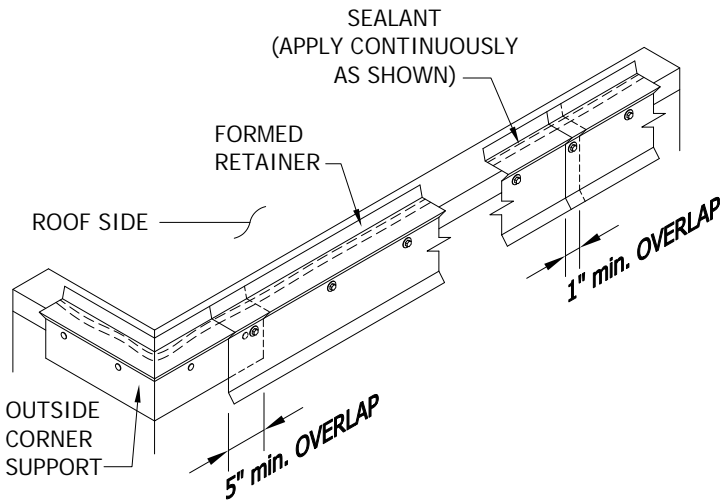

STEP 3: Installing Retainer

Apply a continuous bead of the roofing manufacturer's sealant to the bottom side of the retainer. Set the retainer onto the roof edge over membrane; overlap each corner support at least 5" on each side of the corner support; overlap each adjoining section a minimum of 1". Attach using mechanical screw fasteners (included). Install a fastener in each pre-punched hole.

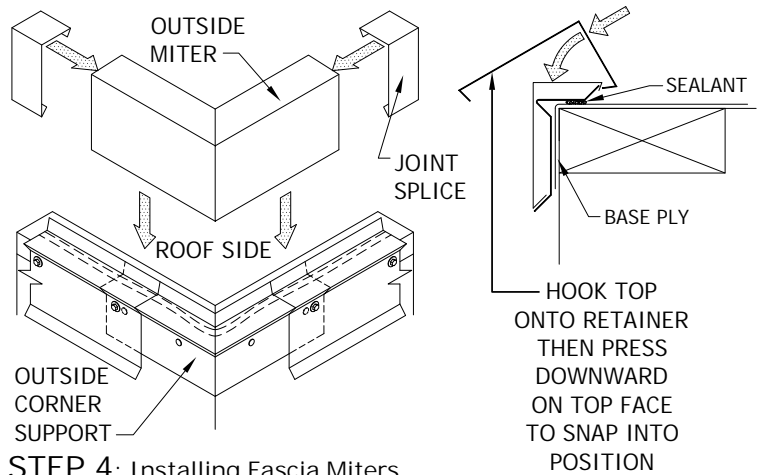

STEP 4: Installing Fascia Miters

Locate the miter and concealed joint splice for the appropriate corner. Place a concealed joint splice in each side of the miter. With splices inside of the retainer, hook the top flange of the miter onto the top flange of the retainer to engage the top. Once the top of the miter has been engaged to the top of the retainer, rotate the fascia outward towards the outside of the building and press down on the top flange of the fascia to snap the bottom hook onto the bottom of the retainer. Make sure that the hook of the fascia has fully engaged onto the retainer.

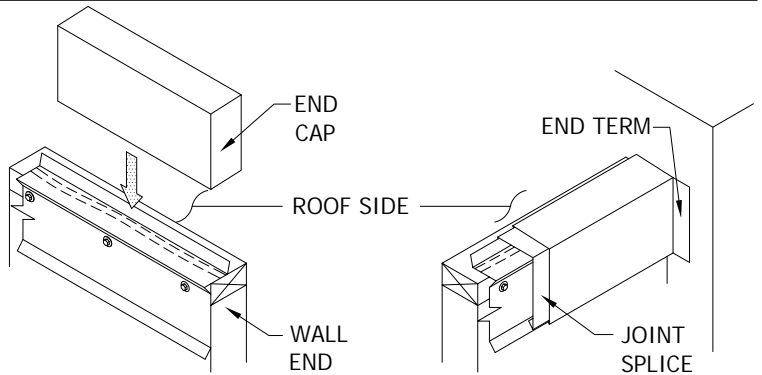

STEP 5: Installing Fascia End Caps and End Terms

Install end caps and end terms by hooking top and pressing top face downward to snap fascia into place (refer to STEP 4).

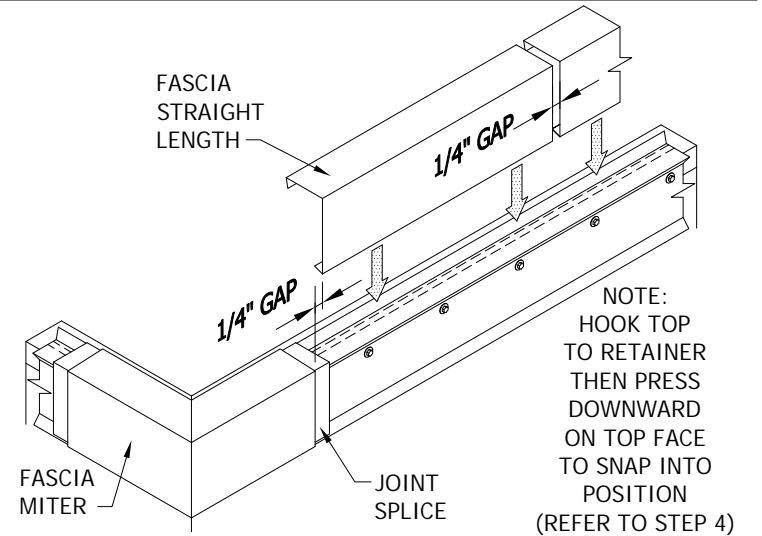

STEP 6: Installing Fascia Straight Lengths

Place a concealed joint splice in the opposite end of the installed miter or end cap. Install the fascia by hooking top and pressing top face downward to snap fascia into place. Allow a 1/4" gap between fascia sections for thermal expansion. Review lengths of all straight pieces prior to cutting to avoid creating relatively short sections of fascia adjacent to full length sections. Note: There must be a joint splice at every joint.

Installation Guide for VersiTrim 3000 - Sump Cores & Spillouts

NOTES:

#1 - Isolate all metal parts from ACQ treated wood or other galvanically incompatible material with appropriate membrane material.
#2 - Appliance attachments, such as lightning rods, signs, or antennae that penetrate the water seal, induce a galvanic reaction, or otherwise compromise the effectiveness of the roof edge system, shall be eliminated or isolated to prevent problems per section 8.0 of ANSI/SPRI ES-1. Appliances should be isolated from or not attached to the roof edge system. Consult the lightning protection system manufacturer for specific attachment instructions.

SUMP CORES

STEP 1: Installing Sump Core

Locate sump cores where downspouts will be located. Sumps are installed prior to the retainer. Fasten sump core to the wood nailer with a min. of (3) 1-1/2" ss ring shank nails.

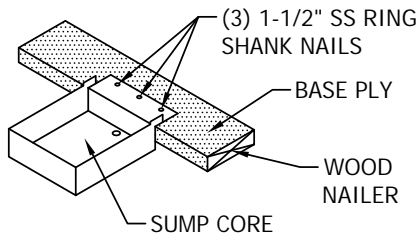

STEP 2: Installing Retainer at Sump Core

Butt retainer to the sump core. Apply membrane flashing strip into the sump core as required by membrane manufacturer's specifications. Splice and seal the membrane in and around the sump core in accordance with membrane manufacturer's specifications.

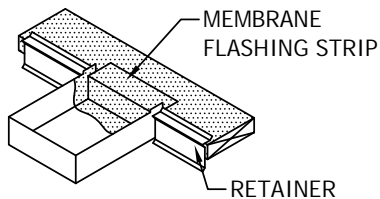

STEP 3: Installing Sump Face

Place a concealed joint splice in each end of sump face. Install sump face by hooking top and pressing top face downward to snap fascia into place.

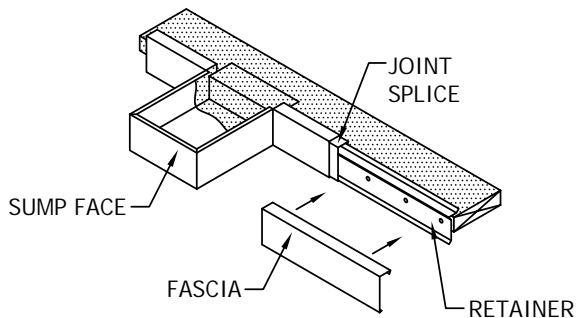

SPILLOUTS

STEP 1: Installing Spillout

Spillouts are installed along with the fascia lengths as required. Spillouts are installed prior to the spring clip. Fasten spillout to the wood nailer with a min. of (2) 1-1/2" ss ring shank nails.

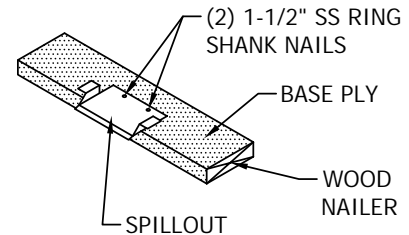

STEP 2: Installing retainer at Spillout

Butt retainer to the spillout. Apply membrane flashing strip into the spillout as required by membrane manufacturer's specifications. Splice and seal the membrane in and around the spillout in accordance with membrane manufacturer's specifications. (DO NOT TO LEAVE ANY SHARP EDGES AGAINST THE MEMBRANE.)

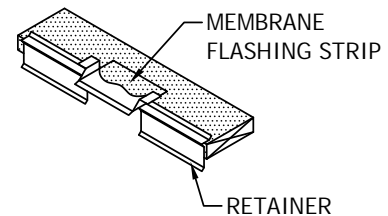

STEP 3: Installing Spillout Face

Place a concealed joint splice in end of fascia. Position spillout fascia in a manner to engage the top of the retainer. Press top face downward to snap fascia into place.

