

# Installation Guide for VersiTrim 300 Fascia

ANSI/SPRI ES-1 TESTED

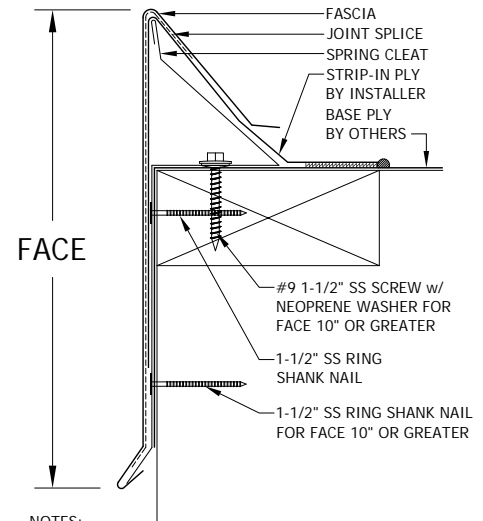

NOTES:  
#1 - Isolate all metal parts from ACQ treated wood or other galvanically incompatible material with appropriate membrane material.  
#2 - Appliance attachments, such as lightning rods, signs, or antennae that penetrate the water seal, induce a galvanic reaction, or otherwise compromise the effectiveness of the roof edge system, shall be eliminated or isolated to prevent problems per section 8.0 of ANSI/SPRI ES-1. Appliances should be isolated from or not attached to the roof edge system. Consult the lightning protection system manufacturer for specific attachment instructions.

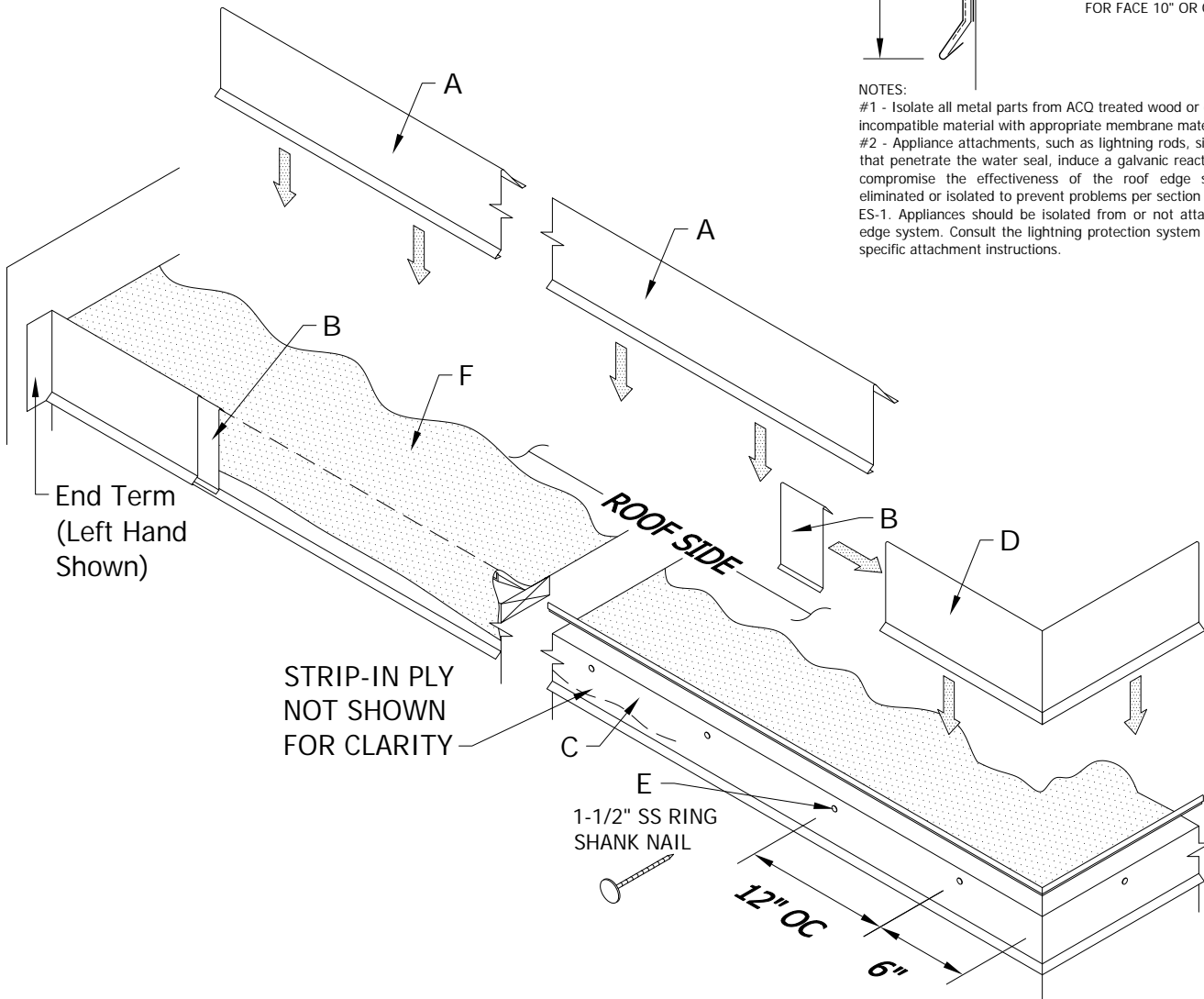

- A. Formed Fascia Cover  
10'-0" Lengths
- B. Concealed Joint Splice  
4" Lengths
- C. Galvanized Steel Spring Cleat  
10'-0" Lengths

- D. Fascia Miter Cover  
(Outside Corner Shown)
- E. 1-1/2" SS Ring Shank Nail  
at 12" o.c. (6" from ends)  
(Included & Required)
- F. Approved Strip-in Ply Membrane  
(By Installer)

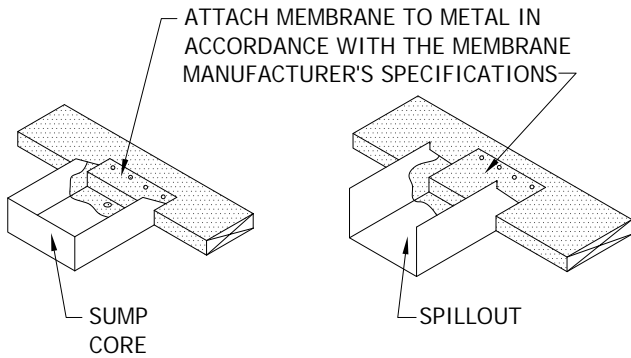

**STEP 1: Consider Sump Core & Spillout Locations**

Locate sump cores where downspouts will be located. Sump cores are installed prior to the spring cleat. The spring cleat butts up to side(s) of sump core. Spillouts are installed along with the fascia lengths as required. Refer to "Spillout & Sump Core Install Guides" for more info on installation if necessary.

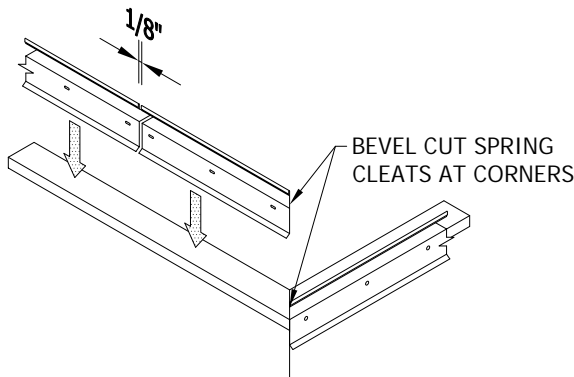

**STEP 2: Installing Spring Cleat**

Prior to installing the spring cleat, ensure that all metal components have been isolated from ACQ treated lumber with appropriate membrane material. Field cut spring cleat to fit corner conditions. Install spring cleat working away from corners. Allow 1/8" gap between sections for thermal movement. Attach the spring cleat using the 1-1/2" ss ring shank nails provided in each pre-punched hole.

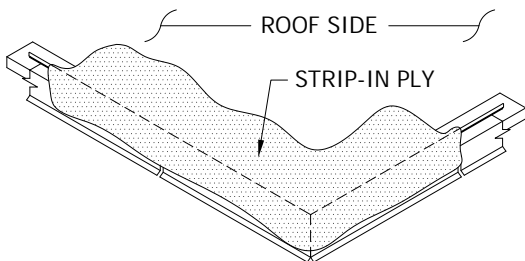

**STEP 3: Installing Strip-in Ply**

Install the strip-in ply in accordance with the manufacturer's specifications. Strip-in ply should extend down the vertical surface of the spring cleat. DO NOT extend past the drip.

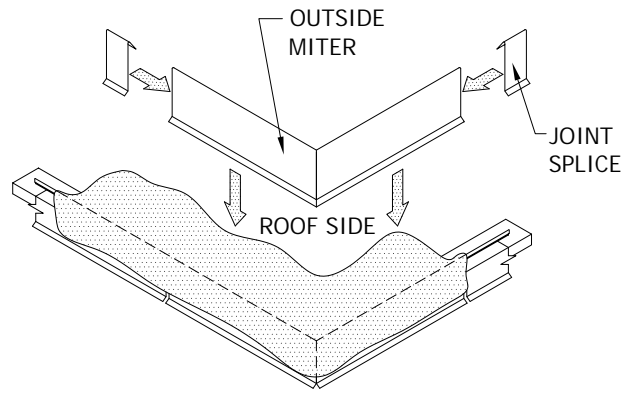

**STEP 4: Installing Fascia Miters**

Locate the miter and concealed joint splice for the appropriate corner. Place a concealed joint splice in each side of the miter. Center the miter over the spring cleat, then press downward on the top of the miter until the drip of the miter fully engages the drip of the spring cleat. Miters have 24" nominal leg lengths.

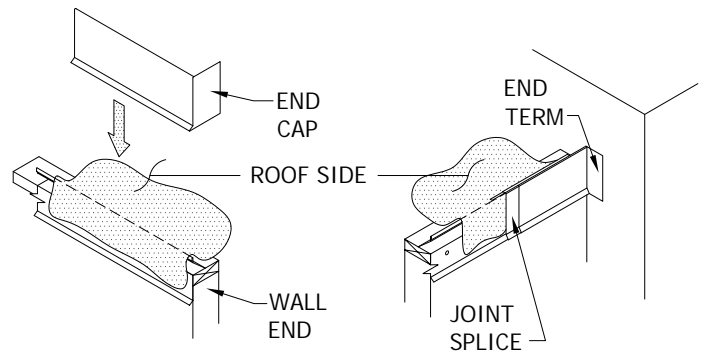

**STEP 5: Installing Fascia End Caps and End Terms**

Install the fascia end caps and end terms by pressing downward on the top flange until the drip of the fascia has fully engaged the drip of the spring cleat.

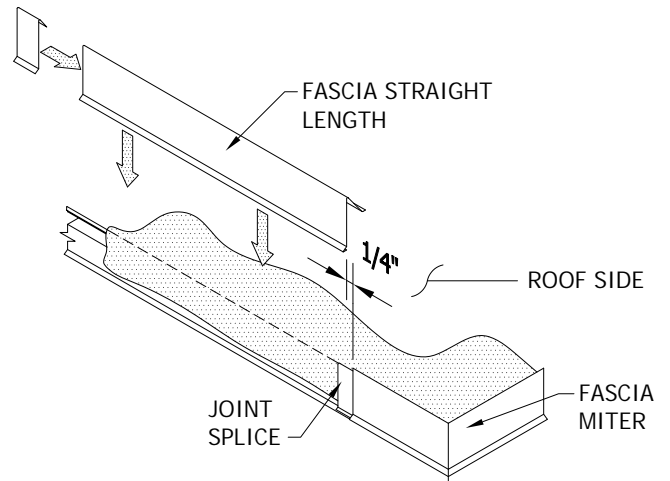

**STEP 6: Installing Fascia Straight Lengths**

Place a concealed joint splice in the opposite end of the installed miter or end cap. Install the fascia by pressing downward on the top flange until the drip of the fascia has fully engaged the drip of the spring cleat. Allow a 1/4" gap between fascia sections for thermal expansion. Consider lengths of all straight pieces prior to cutting to avoid creating relatively short sections of fascia adjacent to full length sections.

Note: There must be a joint splice at every joint.

NOTES:

#1 - Isolate all metal parts from ACQ treated wood or other galvanically incompatible material with appropriate membrane material.

#2 - Appliance attachments, such as lightning rods, signs, or antennae that penetrate the water seal, induce a galvanic reaction, or otherwise compromise the effectiveness of the roof edge system, shall be eliminated or isolated to prevent problems per section 8.0 of ANSI/SPRI ES-1. Appliances should be isolated from or not attached to the roof edge system. Consult the lightning protection system manufacturer for specific attachment instructions.

# Installation Guide for VersiTrim 300 Fascia - Sump Cores & Spillouts

## SUMP CORES

### STEP 1: Installing Sump Core

Locate sump cores where downspouts will be located. Sumps are installed prior to the spring clip. Fasten sump core to the wood nailer with a min. of (3) 1-1/2" ss ring shank nails.

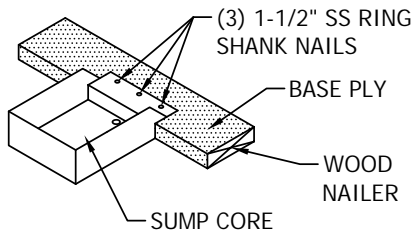

### STEP 2: Installing Spring Clips at Sump Core

Butt spring clip to the sump core. Apply membrane flashing strip over spring clip and into the sump core as required by membrane manufacturer's specifications. Splice and seal the membrane in and around the sump core in accordance with membrane manufacturer's specifications.

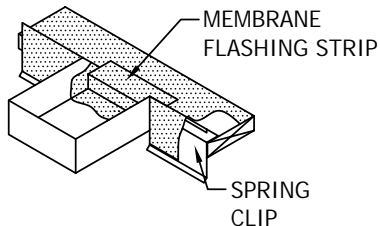

### STEP 3: Installing Sump Face

Place a concealed joint splice in each end of sump face. Install sump face by hooking the fascia snugly over the top of the spring clip. Press down on the fascia until the drip edge is engaged.

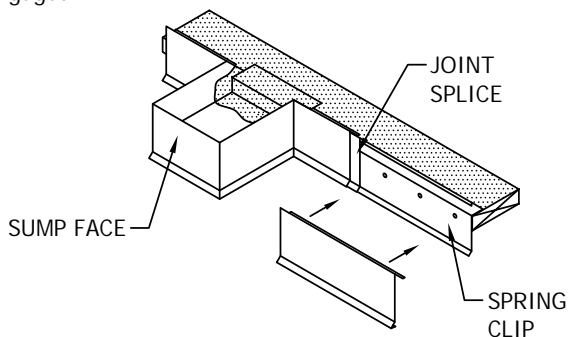

## SPILLOUTS

### STEP 1: Installing Spillout

Spillouts are installed along with the fascia lengths as required. Spillouts are installed prior to the spring clip. Fasten spillout to the wood nailer with a min. of (2) 1-1/2" ss ring shank nails.

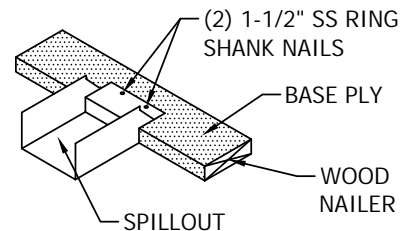

### STEP 2: Installing Spring Clips at Spillout

Butt spring clip to the spillout. Apply membrane flashing strip over spring clip and into the spillout as required by membrane manufacturer's specifications. Splice and seal the membrane in and around the spillout in accordance with membrane manufacturer's specifications. (DO NOT TO LEAVE ANY SHARP EDGES AGAINST THE MEMBRANE.)

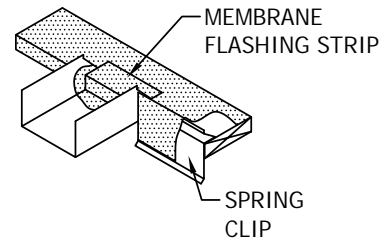

### STEP 3: Installing Spillout Face

Place a concealed joint splice in end of fascia. Place fascia snugly over the top of the spring clip. Press down on the fascia until the drip edge is engaged. Slide fascia into place.

