

Installation Guide for Formed Coping

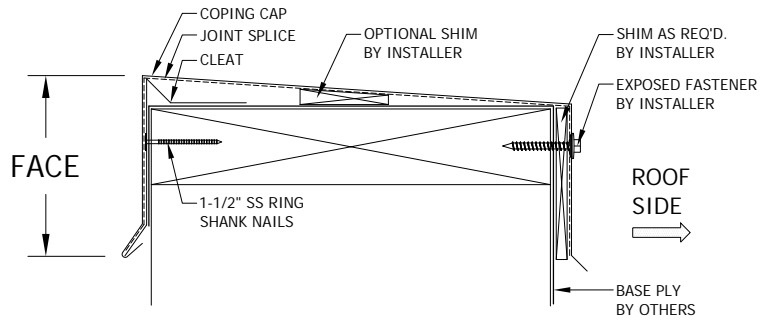

NOTES:
 #1 - Isolate all metal parts from ACQ treated wood or other galvanically incompatible material with appropriate membrane material.
 #2 - Appliance attachments, such as lightning rods, signs, or antennae that penetrate the water seal, induce a galvanic reaction, or otherwise compromise the effectiveness of the roof edge system, shall be eliminated or isolated to prevent problems per section 8.0 of ANSI/SPRI ES-1. Appliances should be isolated from or not attached to the roof edge system. Consult the lightning protection system manufacturer for specific attachment instructions.

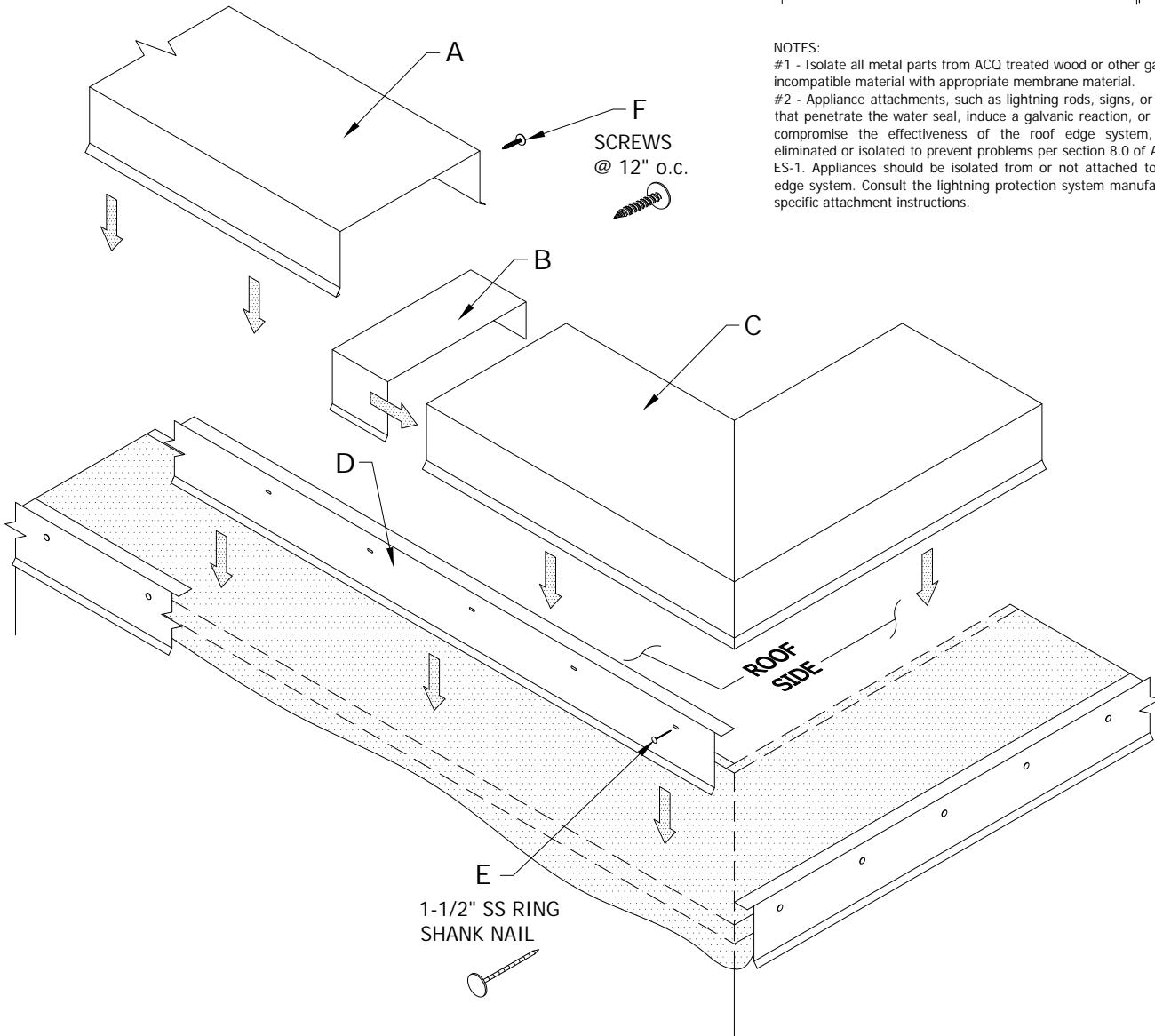

- A. Formed Coping Cap
10'-0" Lengths
- B. Concealed Joint Splice
6" Wide at Each Coping Cap Joint
- C. Coping Miter Cap
(Outside Corner Shown)
- D. Galvanized Steel Cleat
10'-0" Lengths
- E. 1-1/2" SS Ring Shank Nails
at 12" o.c. (6" o.c. within 3'-0" of Corners)
(Included & Required)
- F. Screw Type Fastener w/ Gasket Washer
at 12" o.c.
(By Installer)

W.P. HICKMAN COMPANY

9 Hickman Drive - Asheville, NC 28803 - Phone: (828) 274-4000 - Fax: (828) 274-4031

www.wph.com

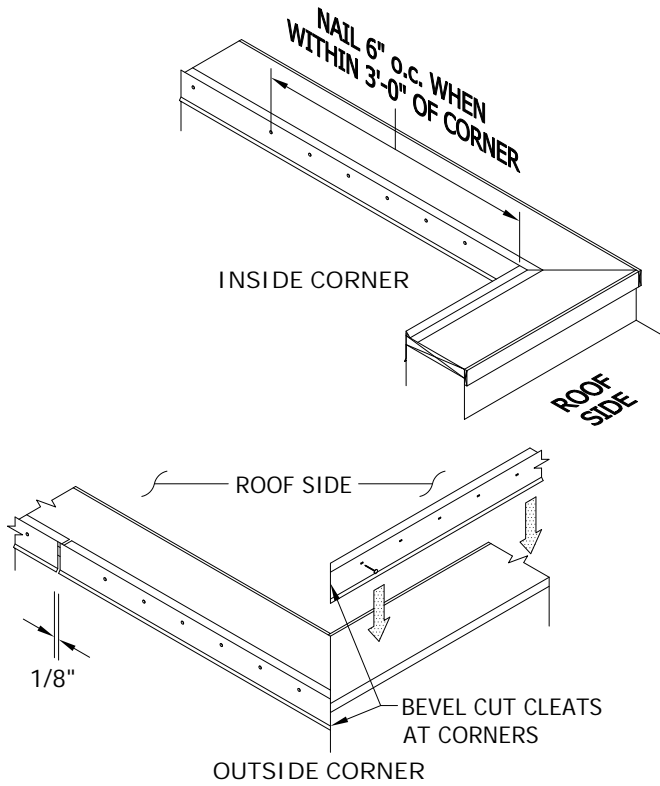

STEP 1: Installing Cleat

Prior to installing the cleat, ensure that all metal components have been isolated from ACQ treated lumber with appropriate membrane material. Field cut cleat to fit corner conditions. Install cleat working away from corners. Allow 1/8" gap between sections for thermal movement. Attach the cleat using the provided 1-1/2" ss ring shank nails in each pre-punched hole; 6" o.c. when nailing within 3'-0" of corners.

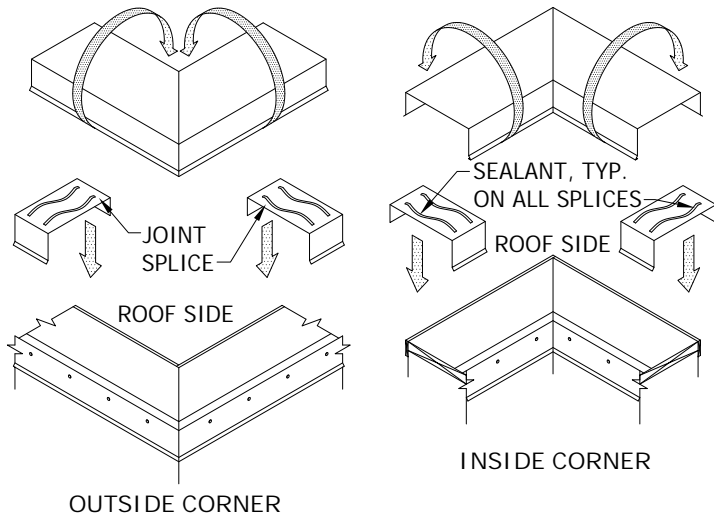

STEP 2: Installing Coping Miters

Locate the miter for the appropriate corner. Place a joint splice on the wall at each end of the coping miter (approx. half way covered by the coping miter). Seal all cap-to-splice junctions with non-hardening sealant. Do not nail joint splices. Hook the drip of the coping miter over the kick out of the cleat, rotate the coping miter over the top of the parapet and screw the roof side leg of the coping @ 12"o.c. w/ screws (by installer).

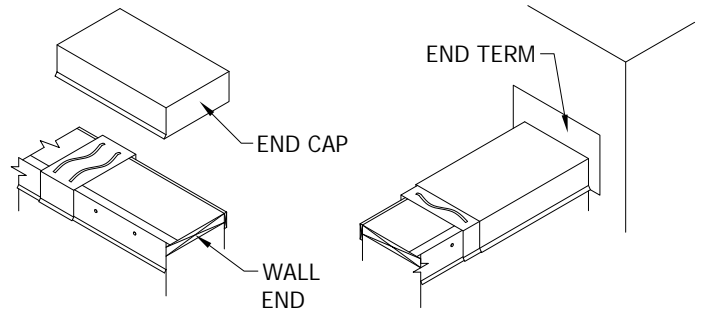

STEP 3: Installing End Caps and End Terms

Install end caps and end terms by hooking the drip over the kick out and rotating the cap over the parapet. End caps and end terms must be restrained from moving by securing it with a min. of (2) screws through the roof side leg. Apply sealant at all joints.

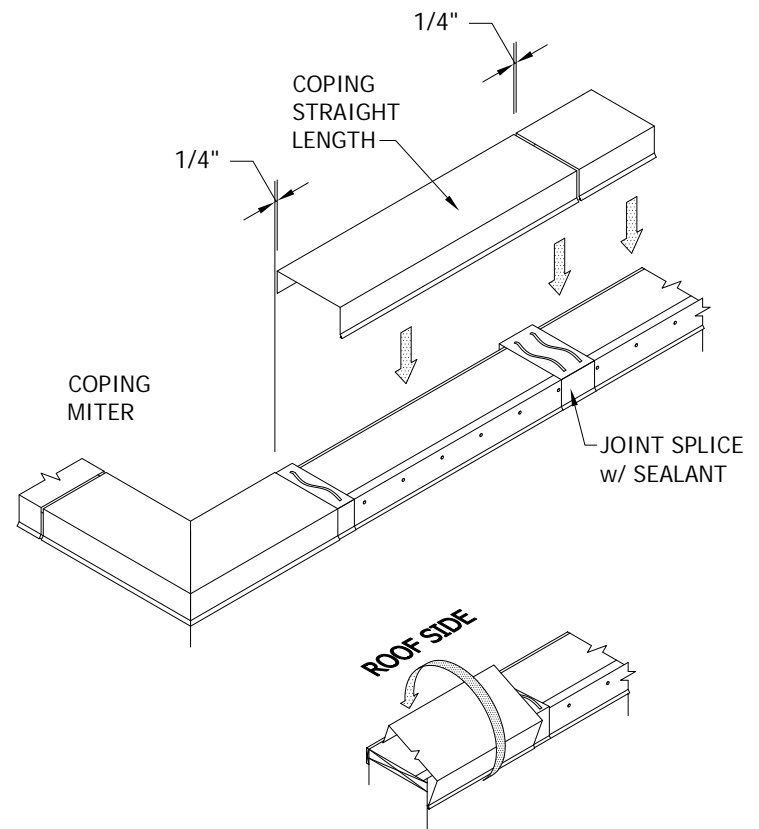

STEP 4: Installing Coping Straight Lengths

Begin installing from the corners and ends working inward to the center. Allow a 1/4" gap between the coping sections for thermal expansion. Review lengths of all straight pieces prior to cutting to avoid creating relatively short sections of cap adjacent to full length sections. Seal all joints between coping cap and joint splices using non-hardening sealant.