

## Installation Guide for DownSpout (OPEN FACE)

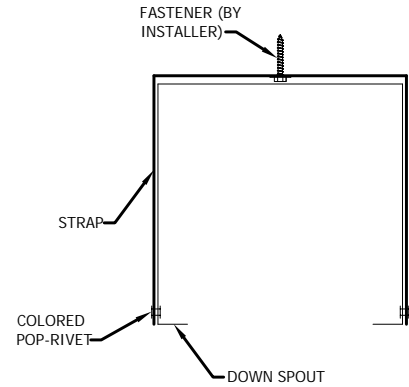
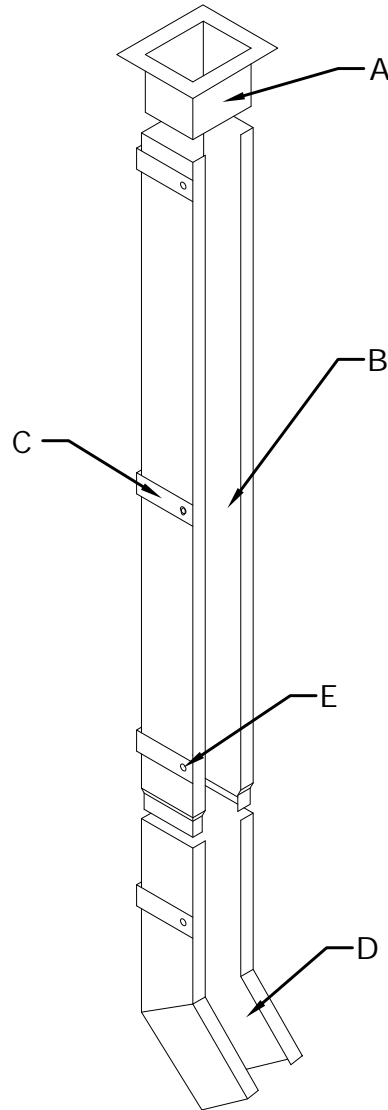

NOTES:

#1 - Isolate all metal parts from ACQ treated wood or other galvanically incompatible material with appropriate membrane material.

#2 - Appliance attachments, such as lightning rods, signs, or antennae that penetrate the water seal, induce a galvanic reaction, or otherwise compromise the effectiveness of the roof edge system, shall be eliminated or isolated to prevent problems per section 8.0 of ANSI/SPRI ES-1. It is recommended that appliances be isolated from or not attached to the roof edge system. Consult the lightning protection system manufacturer for specific attachment instructions.

A. Starter Tube  
At All Downspout Locations

B. DownSpout  
10'-0" Lengths

C. Straps  
3 Per 10'-0" Downspouts

D. Elbows  
(Provided by Manufacturer)

E. Colored Pop-Rivets  
(Provided by Manufacturer)

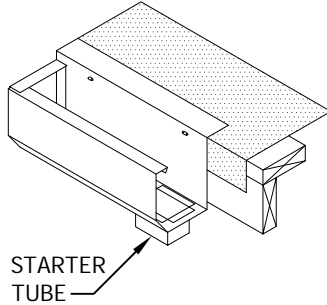

**STEP 1: Installing Starter Tube**

Determine starter tube locations and field cut hole in gutter bottom. Insert starter tube and fasten with 2 rivets in each flange and seal with non-curing sealant.

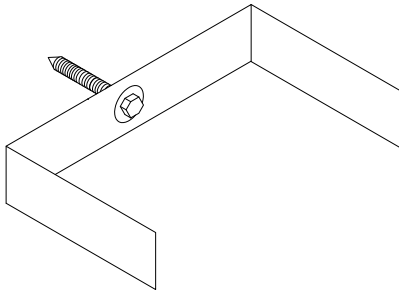

**STEP 2: Installing Straps**

Locate the appropriate straps and secure to wall with mechanical fasteners (by installer). Install 3 per 10'-0" sections, typ. for all straight lengths.

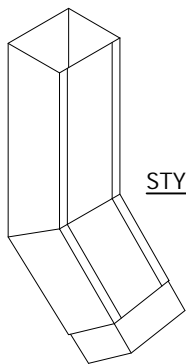

STYLE 1

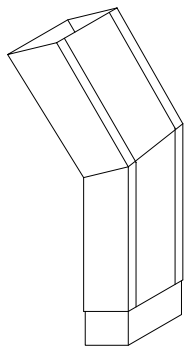

STYLE 2

**STEP 3: Installing Elbow's at Soffit**

Locate appropriate elbows and slide over starter tube, secure and seal at ALL joints.

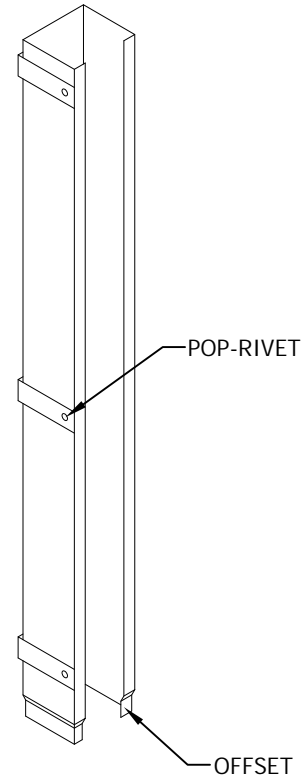

**STEP 4: Installing Downspout Straight Lengths**

Locate appropriate straight lengths, make sure offset end is at the bottom. Secure sections together at joint and seal. Secure to straps using pop-rivets provided by manufacturer.

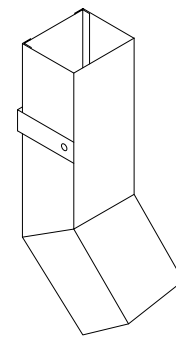

**STEP 5: Installing Downspout Elbow**

Locate appropriate elbows and slide over factory offset, secure and seal at joint.