



Carlisle Syntec Incorporated
 P.O. Box 7000 · Carlisle, PA 17013
 Phone: 800-FOR-SYNTEC FAX: 717-245-7245

SecurEdge 300 Fascia
Order /Specification Form
 (For EPDM)

Factory Mutual Approved*
ANSI/SPRI ES-1 Tested*

* Please contact manufacturer for verification of test report data on your specific project

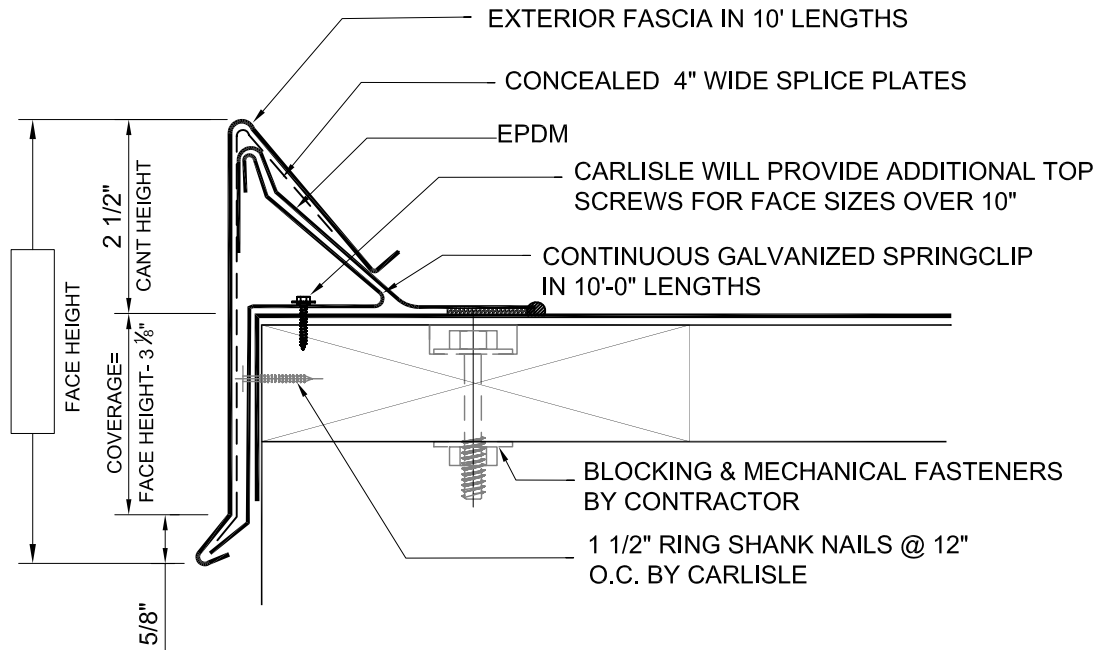

DETAIL:	ARCHITECTURAL REF:	DESCRIPTION:		
QUANTITY, THIS DETAIL _____ TOTAL LF _____ OUTSIDE CORNERS _____ INSIDE CORNERS _____ SPECIAL CORNERS (attach sketches) _____ END CAP - L _____ END CAP - R _____ END TERM - L _____ END TERM - R _____ RADIUS LF _____ RADIUS CORNERS (attach sketches)		MATERIAL <input type="checkbox"/> ALUMINUM <input type="checkbox"/> GALVANIZED <input type="checkbox"/> STAINLESS STEEL <input type="checkbox"/> _____	ACCESSORY TYPE <input type="checkbox"/> WELDED <input type="checkbox"/> METAL-LOCK * IF ACCESSORY TYPE IS NOT CHECKED, WE WILL ASSUME "METAL-LOCK"	FINISH <input type="checkbox"/> MILL FINISH <input type="checkbox"/> PREFINISHED KYNAR <input type="checkbox"/> POST FINISHED KYNAR <input type="checkbox"/> PREFINISHED ANODIZE <input type="checkbox"/> POST FINISHED ANODIZE <input type="checkbox"/> _____ .063 PREFINISHED KYNAR IS ONLY AVAILABLE IN 7 STD. COLORS.
		THICKNESS <input type="checkbox"/> .050 <input type="checkbox"/> .063 <input type="checkbox"/> .080 <input type="checkbox"/> 24 GA <input type="checkbox"/> EXTRUDED (SEE NOTE) <input type="checkbox"/> _____	COLOR _____	
Transmittal <input type="checkbox"/> REQUEST FOR QUOTATION <input type="checkbox"/> SUBMIT FOR APPROVAL <input type="checkbox"/> REQUEST FOR INFORMATION <input type="checkbox"/> CONFIRMING TELECONFERENCE <input type="checkbox"/> FOR YOUR FILES By _____ Date _____		Customer Approval <input type="checkbox"/> APPROVED FOR FABRICATION <input type="checkbox"/> APPROVED AS NOTED <input type="checkbox"/> AMEND & RESUBMIT _____ Authorized Customer Signature _____ Title _____ Date _____		
Job Name		Job #		
Location		Sheet of		
Customer Representative		By		
Architect		Date		

SecurEdge 300 Fascia

Fascia Model	Fascia Face Height in.	Minimum Fascia Gauge in.	Maximum Nailer Thickness Covered in.	Springclip Gauge B&S
SE300-550	5 1/2	.050	2 1/4	24
SE300-700	7	.050	3 3/4	24
SE300-850	8 1/2	.050	5 1/4	24
SE300-1000	10	.063	6 3/4	22

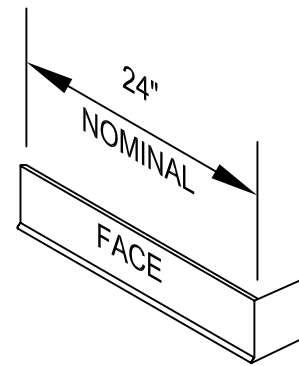

END CAP
RIGHT HAND SHOWN

Intermediate Formed Fascia Sizes May Be Specified Within The Formed Fascia Ranges.

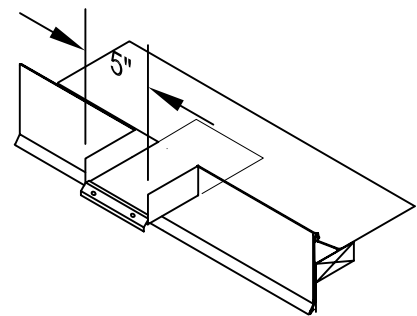

SPILLOUT SCUPPER

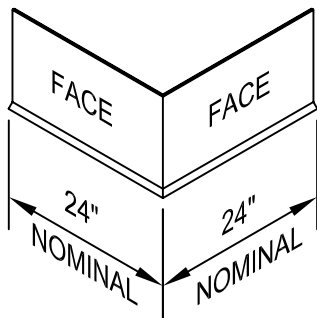

OUTSIDE CORNER

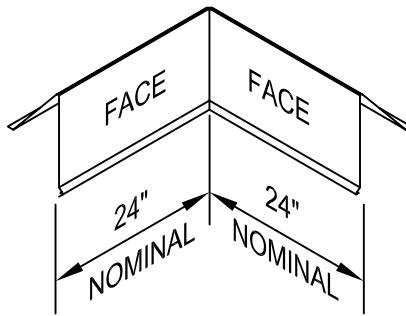

INSIDE CORNER

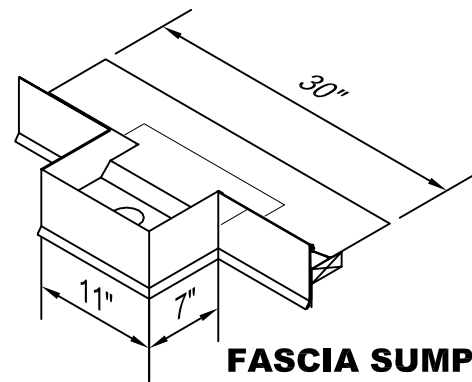

FASCIA SUMP

NOTE: VERIFY ALL INSTALLATION DETAILS FOR ACCEPTANCE BY CARLISLE

STANDARD FASCIA CORNERS ARE 90° - 24" x 24". STANDARD END CAPS ARE 24" LONG.

FOR SPECIAL CORNER REQUIREMENTS, ATTACH SKETCHES. OR CONSULT MFR. FOR ASSISTANCE.

MINIMUM AND MAXIMUM SIZES ARE INDICATED. INTERMEDIATE SIZES MAY BE SPECIFIED WITHIN THESE RANGES. CONSULT MFR. FOR REQUIREMENTS NOT WITHIN THESE RANGES. WHEN FACE SIZE EXCEEDS STD., ADDITIONAL FASTENERS ARE REQUIRED ON FACE OF SPRINGCLIP.

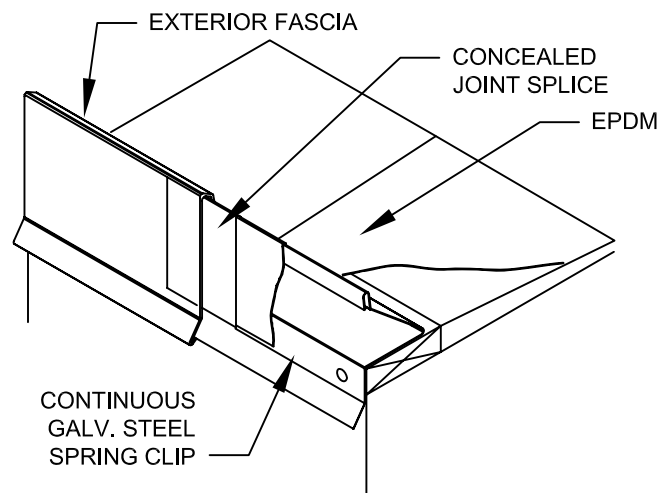

Carlisle Syntec Incorporated
P.O. Box 7000 • Carlisle, PA 17013
Phone: 800-FOR-SYNTEC FAX: 717-245-7245