

DERBIGUM

Roofing Solutions

PERLOK

Conductor Head
Order /Specification Form

4800 Blue Parkway Kansas City, MO 6413C
800.727.9872 Fax: 816.921.5007
www.derbigum.com

NOTE:
"E" & "F" ARE SIZED 1/4" LESS THAN
SIZE OF DOWNSPOUT TO BE USED.

DIM. "A" = 24" MAXIMUM
DIM. "X" = 12" MAXIMUM
DIM. "W" = 18" MAXIMUM

- A = _____
- B = _____
- C = _____
- D = _____
- E = _____
- F = _____
- X = _____
- Y = _____

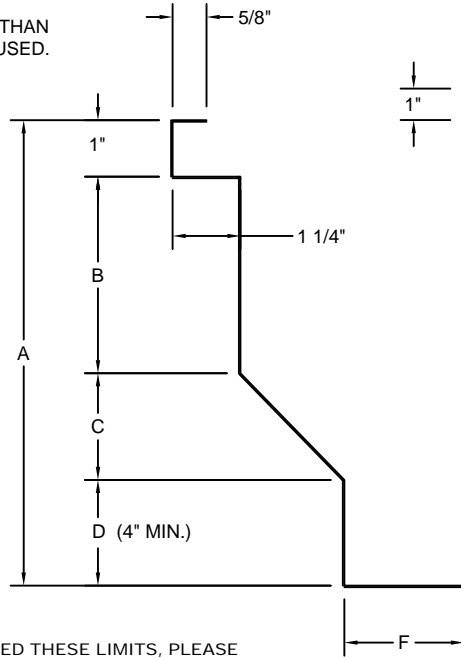

SECTION CUT

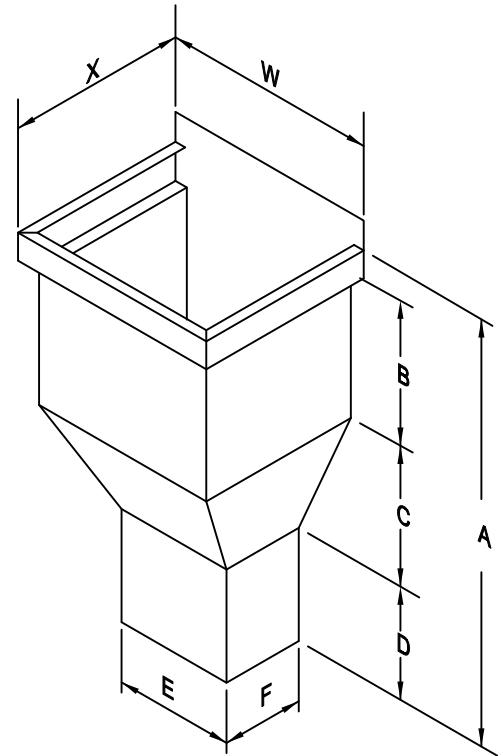

IF YOUR SPECIFICATIONS EXCEED THESE LIMITS, PLEASE
CONTACT PRS FOR SIZES BEYOND THESE LIMITS.

DETAIL:	ARCHITECTURAL REF:	DESCRIPTION:		
QUANTITY, THIS DETAIL _____ PIECES EACH		MATERIAL	TYPE	FINISH
		<input type="checkbox"/> ALUMINUM <input type="checkbox"/> STAINLESS STEEL <input type="checkbox"/> _____	<input type="checkbox"/> WELDED	<input type="checkbox"/> MILL FINISH <input type="checkbox"/> POST FINISHED KYNAR <input type="checkbox"/> POST FINISHED ANODIZE <input type="checkbox"/> _____
		THICKNESS	COLOR _____	
		<input type="checkbox"/> .050 <input type="checkbox"/> .063 <input type="checkbox"/> _____		
Transmittal <input type="checkbox"/> REQUEST FOR QUOTATION <input type="checkbox"/> SUBMIT FOR APPROVAL <input type="checkbox"/> REQUEST FOR INFORMATION <input type="checkbox"/> CONFIRMING TELECONFERENCE <input type="checkbox"/> FOR YOUR FILES By _____ Date _____		Customer Approval <input type="checkbox"/> APPROVED FOR FABRICATION <input type="checkbox"/> APPROVED AS NOTED <input type="checkbox"/> AMEND & RESUBMIT _____ Authorized Customer Signature _____ Title _____ Date _____		
Job Name				Job #
Location				Sheet of
Customer				By
Representative				Date
Architect				G:\A13\ORDERSPEC\CONDUCTOR HEAD\CONDUCTOR HEAD