

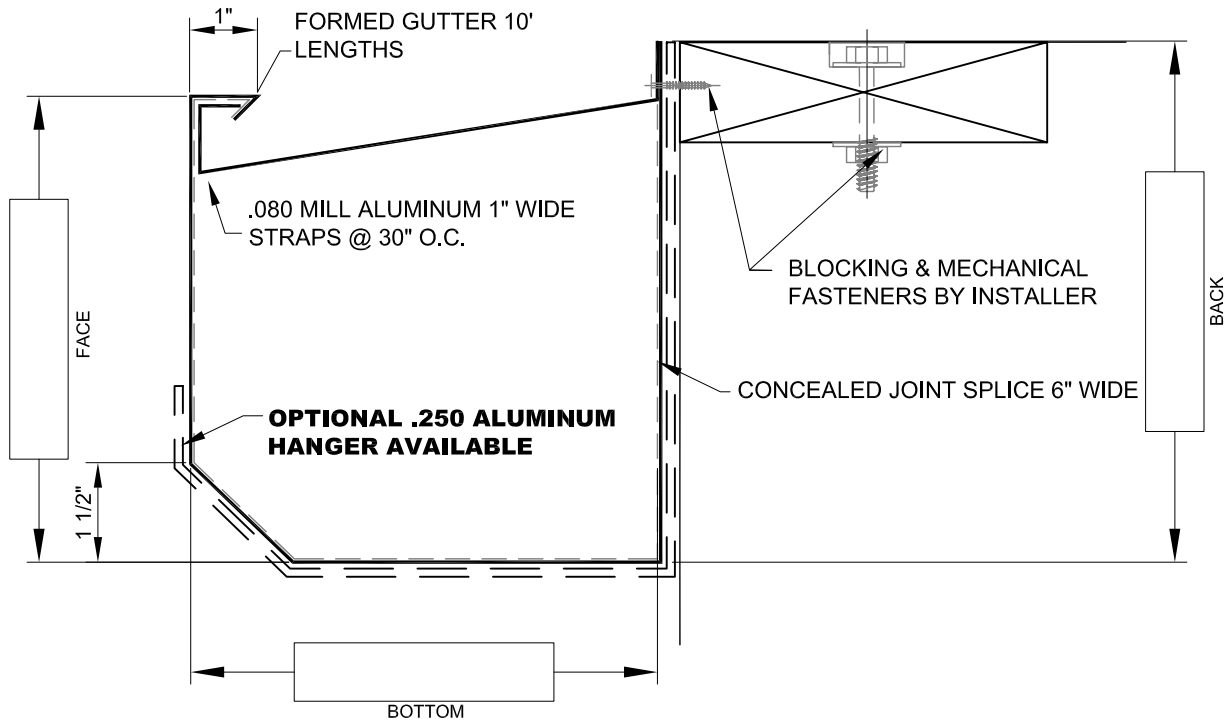

**DERBIGUM®**  
MAKING BUILDINGS SMART

**PERLOK® GUTTER**  
**Order/Specification Form**



<p><b>QUANTITY, THIS DETAIL</b></p> <p>_____ TOTAL LF</p> <p>_____ OUTSIDE CORNERS</p> <p>_____ INSIDE CORNERS</p> <p>_____ SPECIAL CORNERS (attach sketches)</p> <p>_____ END CAP - L</p> <p>_____ END CAP - R</p> <p>_____ EXPANSION JOINTS (INCLUDES 1-RH &amp; 1-LH END CAP)</p>	<p><b>MATERIAL</b></p> <p><input type="checkbox"/> ALUMINUM</p> <p><input type="checkbox"/> GALVANIZED</p> <p><input type="checkbox"/> STAINLESS STEEL</p> <p><input type="checkbox"/> _____</p> <p><b>THICKNESS</b></p> <p><input type="checkbox"/> .040</p> <p><input type="checkbox"/> .050</p> <p><input type="checkbox"/> .063</p> <p><input type="checkbox"/> .080</p> <p><input type="checkbox"/> 24 GA</p> <p><input type="checkbox"/> _____</p>	<p><b>ACCESSORY TYPE</b></p> <p><input type="checkbox"/> WELDED</p> <p><b>* OPTIONAL HANGERS</b></p> <p><input type="checkbox"/> NO</p> <p><input type="checkbox"/> YES</p> <p><b>* IF THIS IS NOT MARKED WE WILL ASSUME NO HANGERS</b></p>	<p><b>FINISH</b></p> <p><input type="checkbox"/> MILL FINISH</p> <p><input type="checkbox"/> PREFINISHED KYNAR</p> <p><input type="checkbox"/> POST FINISHED KYNAR</p> <p><input type="checkbox"/> PREFINISHED ANODIZE</p> <p><input type="checkbox"/> POST FINISHED ANODIZE</p> <p><input type="checkbox"/> _____</p> <p><b>.063 PREFINISHED KYNAR IS ONLY AVAILABLE IN 7 STD. COLORS.</b></p> <p><b>COLOR</b> _____</p>
----------------------------------------------------------------------------------------------------------------------------------------------------------------------------------------------------------------------------------------------------------------------------------------------	----------------------------------------------------------------------------------------------------------------------------------------------------------------------------------------------------------------------------------------------------------------------------------------------------------------------------------------------------------------------------------------------------------------------------------------------------------	---------------------------------------------------------------------------------------------------------------------------------------------------------------------------------------------------------------------------------------------	---------------------------------------------------------------------------------------------------------------------------------------------------------------------------------------------------------------------------------------------------------------------------------------------------------------------------------------------------------------------------------------------------------------------------

<p><b>Transmittal</b></p> <p><input type="checkbox"/> REQUEST FOR QUOTATION</p> <p><input type="checkbox"/> SUBMIT FOR APPROVAL</p> <p><input type="checkbox"/> REQUEST FOR INFORMATION</p> <p><input type="checkbox"/> CONFIRMING TELECONFERENCE</p> <p><input type="checkbox"/> FOR YOUR FILES</p> <p>By _____ Date _____</p>	<p><b>Customer Approval</b></p> <p><input type="checkbox"/> APPROVED FOR FABRICATION</p> <p><input type="checkbox"/> APPROVED AS NOTED</p> <p><input type="checkbox"/> AMEND &amp; RESUBMIT</p> <p>_____</p> <p><b>Authorized Customer Signature</b></p> <p>_____</p> <p><b>Title</b> _____ <b>Date</b> _____</p>
---------------------------------------------------------------------------------------------------------------------------------------------------------------------------------------------------------------------------------------------------------------------------------------------------------------------------------	-------------------------------------------------------------------------------------------------------------------------------------------------------------------------------------------------------------------------------------------------------------------------------------------------------------------

<b>Job Name</b>	<b>Job #</b>
<b>Location</b>	<b>Sheet of</b>
<b>Customer</b>	<b>By</b>
<b>Representative</b>	<b>Date</b>
<b>Architect</b>	

# PERLOK® GUTTER

	<b>FACE</b>	<b>BOTTOM</b>	<b>BACK</b>
	in.	in.	in.
MINIMUM	4	5	5
MAXIMUM	12	14	16

**PLEASE NOTE:  
BOTH BOTTOM AND BACK DIMENSIONS MUST BE  
AT LEAST 1" LARGER THAN THE FACE DIMENSION.**

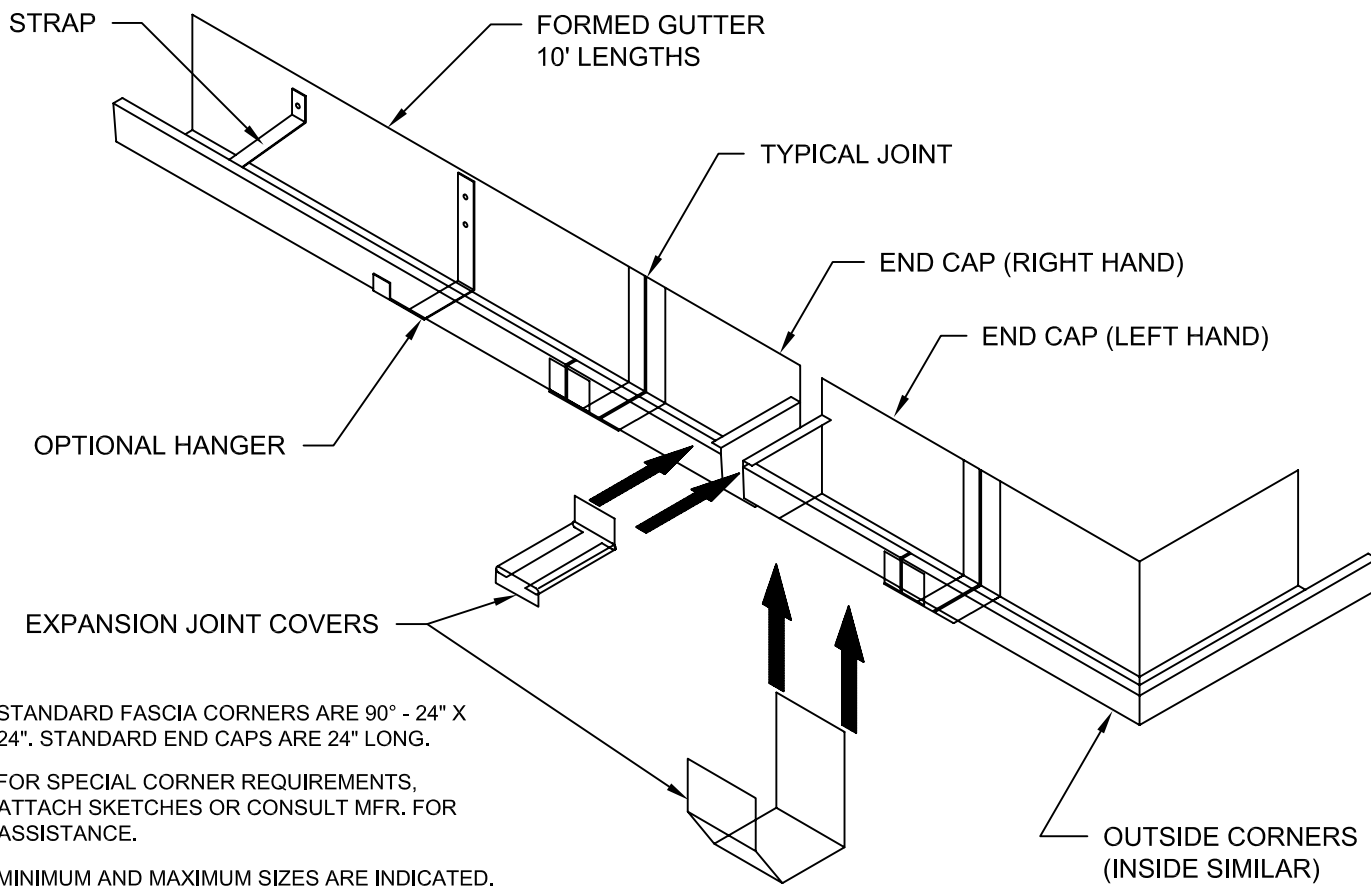

STANDARD FASCIA CORNERS ARE 90° - 24" X 24". STANDARD END CAPS ARE 24" LONG.

FOR SPECIAL CORNER REQUIREMENTS, ATTACH SKETCHES OR CONSULT MFR. FOR ASSISTANCE.

MINIMUM AND MAXIMUM SIZES ARE INDICATED. INTERMEDIATE SIZES MAY BE SPECIFIED WITHIN THESE RANGES. CONSULT MFR. FOR REQUIREMENTS NOT WITHIN THESE RANGES.

# DERBIGUM®

**PERFORMANCE**  
ROOF SYSTEMS

4800 Blue Parkway  
Kansas City, MO 64130  
Phone: 800-727-9872 Fax: 816-921-5007  
Email: info@derbigum.com - www.derbigum.com