

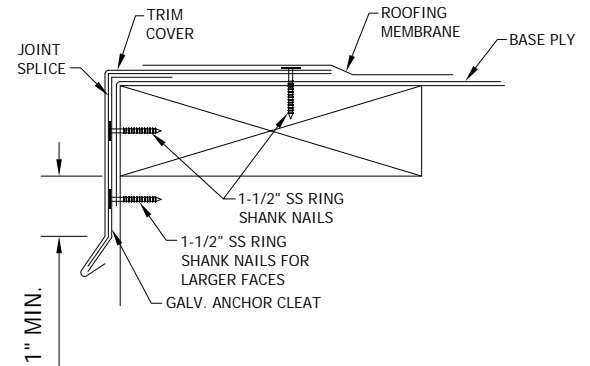

# Installation Guide for Sure-Seal Drip Edge

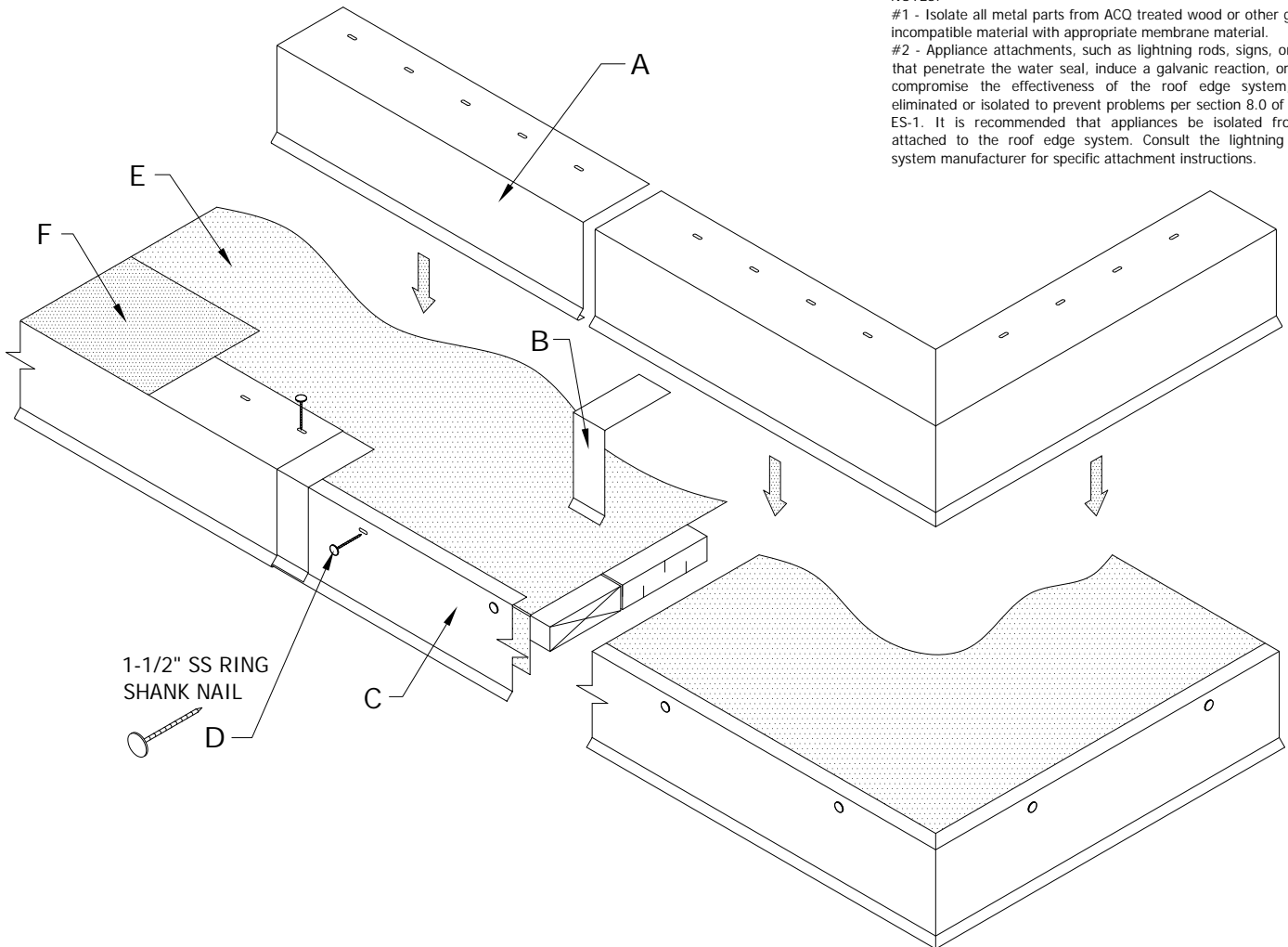

NOTES:  
#1 - Isolate all metal parts from ACQ treated wood or other galvanically incompatible material with appropriate membrane material.  
#2 - Appliance attachments, such as lightning rods, signs, or antennae that penetrate the water seal, induce a galvanic reaction, or otherwise compromise the effectiveness of the roof edge system, shall be eliminated or isolated to prevent problems per section 8.0 of ANSI/SPRI ES-1. It is recommended that appliances be isolated from or not attached to the roof edge system. Consult the lightning protection system manufacturer for specific attachment instructions.



- A. Formed Trim Cover  
10'-0" Lengths
- B. Concealed Joint Splice  
4" Lengths
- C. Galvanized Anchor Cleat  
10'-0" Lengths

- D. 1-1/2" SS Ring Shank Nail  
at 12" o.c. (6" from ends) for clip  
at 6" o.c. (6" from ends) for face  
(Provided & Required by Manufacturer)
- E. Base Ply  
(By Installer)
- F. Approved Roofing Membrane  
(By Installer)

CARLISLE SYNTEC INCORPORATED  
P.O. BOX 7000 - CARLISLE, PA 17013 - Phone: (800) FOR-SYNTEC - Fax: (717) 245-7245

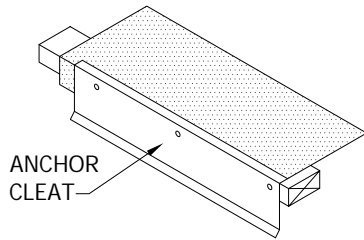

### STEP 1: Installing Anchor Cleat

Place the top lip of the continuous anchor cleat squarely on the top edge of the roofing membrane and treated wood nailing plate. Press cleats securely in position and nail through the pre-punched holes with 1-1/2" ss ring shank nails provided. For miter application, fit into corner as required to maintain a continuous anchor cleat line. Then nail at a min. 6" on center in each direction from the corner or closer at special conditions.

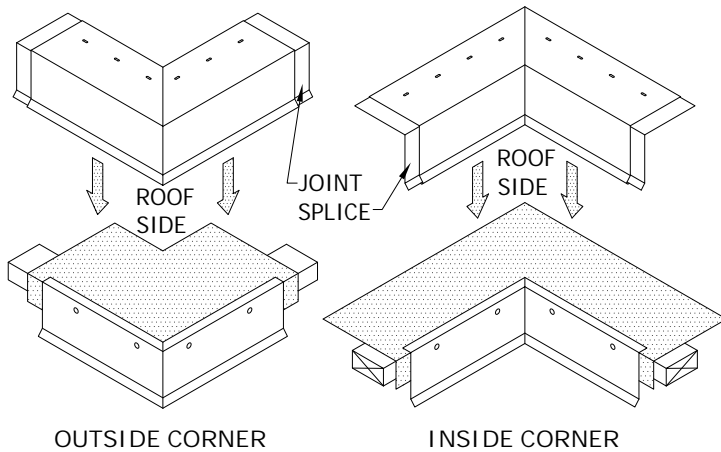

### STEP 2: Installing Trim Miters

Locate the miters and concealed joint splices for the appropriate corners. Place a concealed joint splice under each end of the miter sections. Install the miter by hooking the drip of the trim miter onto the drip of the cleat and rotate back onto the roof. Fasten with 1-1/2" ss ring shank nails provided in each pre-punched hole.

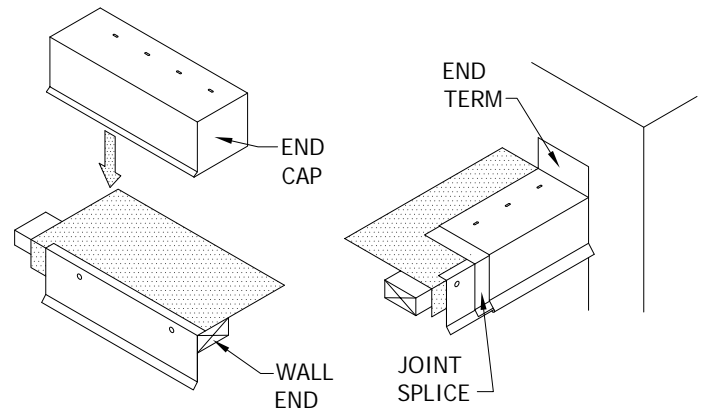

### STEP 3: Installing Trim End Caps and End Terms

Install the trim end caps and end terms by hooking the drip of the trim onto the drip of the cleat and rotate back onto the roof. Fasten with 1-1/2" ss ring shank nails provided in each pre-punched hole.

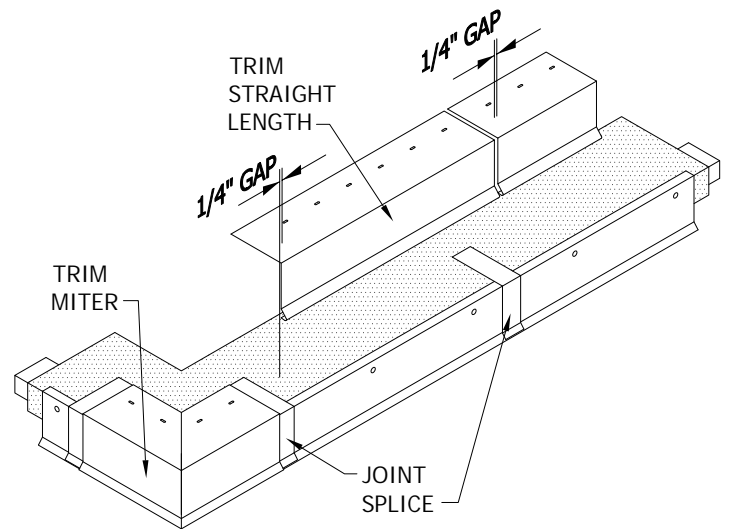

### STEP 4: Installing Trim Straight Lengths

Place a concealed joint splice in the opposite end of the installed miter or end cap. Install the trim by hooking the drip of the trim onto the drip of the cleat and rotate back onto the roof. Fasten with 1-1/2" ss ring shank nails provided in each pre-punched hole. Allow 1/4" gap between trim sections for thermal expansion. Lengths of all straight pieces should be considered prior to cutting to avoid creating relatively short sections of trim adjacent to full length sections.

Note: there should be a joint splice at every joint.

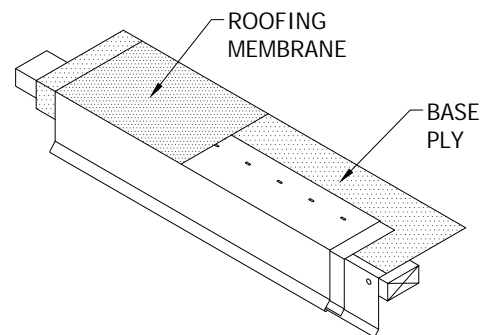

### STEP 5: Installing Approved Roofing Membrane

Install roofing membrane per manufacturer's instructions.